



ASKEY



ASKEY MOBILE COMPUTER

RC40 User Guide

Powered by Android™ 14

Copyright © 2025, Askey Computer Corp. All rights reserved.

ABOUT

The **RC40** rugged mobile computer is designed and manufactured by Askey Computer Corporation. Featuring the Qualcomm® QCM 4490 processor to offer the latest in processing power and excellent performance, along with integrated bar code scanning data capture from Honeywell with the N5703SR standard range, or optional advanced long range N6803LR bar code imagers for outstanding automatic data capture capabilities.

RC40 equips wireless 5G NR to offer the best possible voice and data performance inside and outside your operations, fast Wi-Fi connectivity with IEEE 802.11a/b/g/n/ac/d/r/k/h/i/w/v/ax include 2.4GHz/5GHz/6GHz; CBRS (Citizens Broadband Radio Service) with LTE and 5G private network (CBRS), to improve coverage, security, QoS; Bluetooth 5.2 with Bluetooth low energy; NFC (Near Field Communication); front 8MP AF and rear 16MP AF cameras; USB-C connector to support charge and communication; and support PTT (Push To Talk) feature.

RC40 supports warm swap field battery replacement to help to reduce the data loss risk when power runs out and eliminating the need to take the device out of use for charging.

Due to continuous product development, the SW and this guide will keep updating to give you a better user experience. Information in this document is subject to change without notice.

Copyright

Copyright © 2025, Askey Computer Corp. All rights reserved.

TradeMark

Google, Android, Google Play and other marks are trademarks of Google LLC.

All other trademarks are the property of their respective owners.

CONTENT LIST

About	1
Content List	2
1. Important Notices and Precautions	6
1.1 Regulatory Guide	6
1.1.1 Federal Communication Commission Interference Statement	6
1.1.2 Industry Canada statement	7
1.2 Safety Guide	10
1.3 Customer Support	15
1.4 Product warranty	15
2. Getting started	16
2.1 Introduce	16
2.2 Production Detail	16
2.3 Package Content	20
2.4 Accessory (available for purchase)	21
2.5 Installation	21
2.5.1 Install/Remove Battery	21
2.5.2 Install/Remove SIM/SD Card	22
2.5.3 Charging Cradle	24
2.5.4 USB Charger	29
3. Basic operation	31
3.1 Power on/off the Device	31
3.2 Welcome	31
3.3 Battery	32
3.3.1 Main Battery	32
3.3.2 Backup Battery	32
3.3.3 Battery Status	32
3.3.4 Low Battery Alert	33
3.3.5 Main Battery SWAP	33
3.3.6 Battery OverHeat protection	35
3.3.7 Battery management	36
3.4 Memory	38
3.4.1 Storage Management	39
3.4.2 Data Transferring	40
3.5 Phone	41
3.5.1 Phone Application	41
3.5.2 Contact add	41
3.5.3 During calling	42
3.5.4 Incoming call	42

3.5.5 Recents -----	43
3.5.6 Call Settings-----	44
3.6 Display -----	44
3.6.1 Home -----	44
3.6.2 Touch Panel control -----	46
3.6.3 Lock and Unlock Screen -----	46
3.7 Data Capture -----	46
3.7.1 EZwedge-----	46
3.7.2 Barcode Scanning -----	75
3.8 Camera -----	76
3.8.1 Camera Function -----	76
3.8.2 Photos Taking Function -----	76
3.8.3 Video Recording Function -----	77
3.8.4 Settings -----	77
3.9 QUICK SETTINGS MANAGEMENT-----	79
4. Settings -----	82
4.1 Display -----	82
4.1.1 Brightness-----	82
4.1.2 Lock Display -----	82
4.1.3 Interaction -----	83
4.2 Notification -----	84
4.2.1 Manage -----	84
4.2.2 Conversation -----	85
4.2.3 Show Notification -----	85
4.2.4 General -----	85
4.3 Sound & Vibration -----	86
4.3.1 Audio Output-----	86
4.3.2 Volume-----	87
4.3.3 Vibration -----	88
4.4 Wallpaper -----	89
4.5 Accessibility-----	90
4.5.1 SCREEN READER-----	90
4.5.2 DISPLAY-----	90
4.5.3 INTERACTION CONTROLS -----	91
4.5.4 CAPTIONS -----	91
4.5.5 AUDIO-----	92
4.5.6 GENERAL -----	92
4.6 SECURITY -----	93
4.6.1 Security status -----	93

4.6.2 Device Security -----	94
4.7 Privacy-----	94
4.8 Location-----	96
4.8.1 Go to "Location" settings -----	96
4.8.2 Enable or disable location -----	97
4.8.3 Recent Location Access management-----	98
4.8.4 App location permission management-----	98
4.9 Safety & Emergency-----	99
4.10 Passwords & accounts-----	101
4.10.1 PASSWORD-----	102
4.10.2 AUTOFILL SERVICE -----	102
4.10.3 ACCOUNTS FOR OWNER -----	103
4.11 Digital wellbeing & parental control -----	105
4.12 GOOGLE -----	107
4.13 System-----	110
4.14 MAGIC KEYS-----	111
5. Connection-----	115
5.1 Internet -----	115
5.2 Wi-Fi -----	117
5.3 Bluetooth-----	0
5.4 NFC -----	0
6. Application deployment -----	0
6.1 About EZClone -----	0
6.1.1 Download -----	0
6.1.2 Installation -----	0
6.1.3 Main Function-----	0
6.1.4 Settings Page-----	0
6.1.5 Device Reset Page-----	0
6.1.6 Provisioning Page -----	0
6.1.7 QR Codes Page-----	0
6.1.8 Export Page -----	0
6.1.9 Import Page -----	0
6.1.10 Theme Page-----	0
6.1.11 About Page -----	0
6.1.12 Device EZClone APP-----	0
6.1.13 Start firmware upgrade-----	0
6.1.14 Upgrade software version through system Settings-----	0
6.2 EZ PTT User Guide -----	0
6.2.1 About EZ PTT -----	0
6.2.2 Main Function -----	0

6.2.3 Group Calls	0
6.2.4 Contacts Page	0
6.2.5 Private calls	0
6.2.6 Settings Page	0
7. Accessories	0
7.1 Install Hand Strap (need to purchase add-on accessory)	0
7.2 Install Pistol (need to purchase add-on accessory)	0
8. Maintain and Trouble shooting	0
8.1 Maintenance	0
Appendix	0

1. IMPORTANT NOTICES AND PRECAUTIONS

1.1 REGULATORY GUIDE

1.1.1 FEDERAL COMMUNICATION COMMISSION INTERFERENCE STATEMENT

This device complies with Part 15 of the FCC Rules. Operation is subject to the following two conditions: (1) This device may not cause harmful interference, and (2) this device must accept any interference received, including interference that may cause undesired operation.

This equipment has been tested and found to comply with the limits for a Class B digital device, pursuant to Part 15 of the FCC Rules. These limits are designed to provide reasonable protection against harmful interference in a residential installation. This equipment generates, uses and can radiate radio frequency energy and, if not installed and used in accordance with the instructions, may cause harmful interference to radio communications. However, there is no guarantee that interference will not occur in a particular installation. If this equipment does cause harmful interference to radio or television reception, which can be determined by turning the equipment off and on, the user is encouraged to try to correct the interference by one of the following measures:

- Reorient or relocate the receiving antenna.
- Increase the separation between the equipment and receiver.
- Connect the equipment into an outlet on a circuit different from that to which the receiver is connected.
- Consult the dealer or an experienced radio/TV technician for help.

FCC Caution: Any changes or modifications not expressly approved by the party responsible for compliance could void the user's authority to operate this equipment.

This transmitter must not be co-located or operating in conjunction with any other antenna or transmitter.

Application	Frequency Range	Power
NFC	13.56 MHz	30 dBuV/m at 30m
Bluetooth	2400-2485 MHz	-6 ~ 4 dBm
Wireless Lan (802.11 a/b/g/n/ac/ax)	2400-2485 MHz 5150-5250 MHz 5250-5350 MHz 5470-5725 MHz	< 30 dBm < 30 dBm < 24 dBm < 24 dBm

	5745-5825 MHz 5925-7125 MHz	< 30 dBm < 24 dBm
LTE	B2,B4,B5,B12,B13,B14,B17,B25,B26,B30, B38,B41,B42,B43,B48,B53,B66,B70,B71	< 23 dBm
5G NR	n2,n5,n7,n12,n13,n14,n25,n26,n30,n38, n48,n53,n66,n70,n71	< 23 dBm
	N41,n77,n78	< 26 dBm

1.1.1.1 FOR PORTABLE DEVICE USAGE

Radiation Exposure Statement:

The product complies with the FCC portable RF exposure limit set forth for an uncontrolled environment and is safe for intended operation as described in this manual. Further RF exposure reduction can be achieved if the product can be kept as far as possible from the user body or set the device to lower output power if such function is available.

1.1.1.2 BODY-WORN OPERATION

This device was tested for typical body-worn operations. To comply with RF exposure requirements, a minimum separation distance of 5 mm must be maintained between the user's body and the handset, including the antenna. Third-party belt-clips, holsters, and similar accessories used by this device should not contain any metallic components. Body-worn accessories that do not meet these requirements may not comply with RF exposure requirements and should be avoided.

1.1.1.3 FOR 6XD (INDOOR CLIENT)

Transmitters in the 5.925-7.125 GHz band are prohibited from operating to control or communicate with unmanned aircraft systems.

1.1.2 INDUSTRY CANADA STATEMENT

This device complies with ISED's licence-exempt RSSs. Operation is subject to the following two conditions: (1) This device may not cause harmful interference, and (2) this device must accept any interference received, including interference that may cause undesired operation.

Le présent appareil est conforme aux CNR d'ISED applicables aux appareils radio exempts de licence. L'exploitation est autorisée aux deux conditions suivantes : (1) le dispositif ne doit pas produire de brouillage préjudiciable, et (2) ce dispositif doit

accepter tout brouillage reçu, y compris un brouillage susceptible de provoquer un fonctionnement indésirable.

Caution:

(i) the device for operation in the band 5150-5250 MHz is only for indoor use to reduce the potential for harmful interference to co-channel mobile satellite systems;

(ii) where applicable, antenna type(s), antenna models(s), and worst-case tilt angle(s) necessary to remain compliant with the e.i.r.p. elevation mask requirement set forth in section 6.2.2.3 shall be clearly indicated.

Avertissement:

Le guide d'utilisation des dispositifs pour réseaux locaux doit inclure des instructions précises sur les restrictions susmentionnées, notamment :

(i) les dispositifs fonctionnant dans la bande 5150-5250 MHz sont réservés uniquement pour une utilisation à l'intérieur afin de réduire les risques de brouillage préjudiciable aux systèmes de satellites mobiles utilisant les mêmes canaux;

(ii) lorsqu'il y a lieu, les types d'antennes (s'il y en a plusieurs), les numéros de modèle de l'antenne et les pires angles d'inclinaison nécessaires pour rester conforme à l'exigence de la p.i.r.e. applicable au masque d'élévation, énoncée à la section 6.2.2.3, doivent être clairement indiqués

1.1.2.1 FOR PORTABLE DEVICE USAGE

Radiation Exposure Statement:

The product complies with the Canada portable RF exposure limit set forth for an uncontrolled environment and is safe for intended operation as described in this manual. Further RF exposure reduction can be achieved if the product can be kept as far as possible from the user body or set the device to lower output power if such function is available.

Déclaration d'exposition aux radiations:

Le produit est conforme aux limites d'exposition pour les appareils portables RF pour les Etats-Unis et le Canada établies pour un environnement non contrôlé.

Le produit est sûr pour un fonctionnement tel que décrit dans ce manuel. La réduction aux expositions RF peut être augmentée si l'appareil peut être conservé aussi loin que possible du corps de l'utilisateur ou que le dispositif est réglé sur la puissance de sortie la plus faible si une telle fonction est disponible.

1.1.2.2 BODY-WORN OPERATION

This device was tested for typical body-worn operations. To comply with RF exposure requirements, a minimum separation distance of 5 mm must be maintained between the user's body and the handset, including the antenna. Third-party belt-clips, holsters, and similar accessories used by this device should not contain any metallic components. Body-worn accessories that do not meet these requirements may not comply with RF exposure requirements and should be avoided.

Cet appareil a été testé pour un fonctionnement porté sur le corps. Pour respecter les exigences d'exposition aux radiofréquences, une distance minimale de 5 mm doit être respectée entre le corps de l'utilisateur et le combiné, antenne comprise. Les clips de ceinture, étuis et accessoires similaires d'autres marques utilisés avec cet appareil ne doivent contenir aucun composant métallique. Les accessoires portés sur le corps qui ne répondent pas à ces exigences peuvent ne pas être conformes aux exigences d'exposition aux radiofréquences et doivent être évités.

1.1.2.3 FOR 6E STATEMENT IN MANUAL

RSS-248 Issue 3 General statement (all equipment class)

- Devices shall not be used for control of or communications with unmanned aircraft systems.
- Devices shall not be used on oil platforms.
- Devices shall not be used on aircraft, except for the low-power indoor access points, indoor subordinate devices, low-power client devices, and very low-power devices operating in the 5925-6425 MHz band, that may be used on large aircraft as defined in the Canadian Aviation Regulations, while flying above 3,048 metres (10,000 feet).
- Devices shall not be used on automobiles.
- Devices shall not be used on trains.
- Devices shall not be used on maritime vessels.

- Les dispositifs ne doivent pas être utilisés pour commander des systèmes d'aéronef sans pilote ni pour communiquer avec de tels systèmes;
- Les dispositifs ne doivent pas être utilisés sur les plateformes de forage pétrolier;
- Les dispositifs ne doivent pas être utilisés dans les aéronefs, à l'exception des points d'accès intérieurs de faible puissance, des dispositifs subordonnés intérieurs, des

dispositifs clients de faible puissance et des dispositifs de très faible puissance fonctionnant dans la bande de 5 925 à 6 425 MHz, qui peuvent être utilisés dans les gros aéronefs tel qu'il est défini dans le Règlement de l'aviation canadien, et ce, lorsqu'ils volent à une altitude supérieure à 3 048 mètres (10 000 pieds).

- Les dispositifs ne doivent pas être utilisés dans les automobiles;
- Les dispositifs ne doivent pas être utilisés dans les trains;
- Les dispositifs ne doivent pas être utilisés sur les navires maritimes.

1.2 SAFETY GUIDE

Laser Devices

Class 2 laser scanners use a low power, visible light diode. As with any very bright light source such as the sun, the user should avoid staring directly into the light beam. Momentary exposure to a Class 2 laser is not known to be harmful.

Laser beam divergence for scanner module:

- For model N5703SR: $\theta_{//}$ 12 deg., θ_{\perp} 14 deg.
- For model N6803LR: $\theta_{//}$ 12 deg., θ_{\perp} 12 deg.

CAUTION: Use of controls, adjustments, or the performance of procedures other than those specified herein may result in hazardous laser light exposure.

 LASER LIGHT- DO NOT STARE INTO BEAM. CLASS 2 LASER PRODUCT.

 RAYONNEMENT LASER- NE PAS REGARDER DANS LE FAISCEAU. PRODUITS LASER DE CLASS 2.

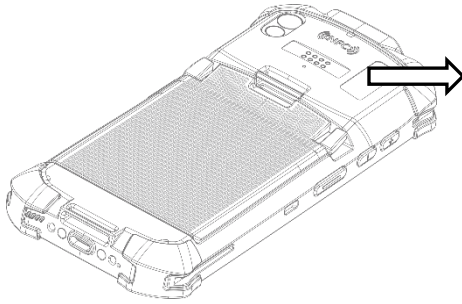

**LASER LIGHT- DO NOT STARE INTO BEAM.
RAYONNEMENT LASER NE PAS REGARDER
DANS LE FAISCEAU. MAX. 1mW:630-680nm.**



IEC 60825-1:2014. Pulse duration of 16.8mSec. Complies with 21 CFR 1040.10 and 1040.11 except for conformance with IEC 60825-1 Ed. 3., as described in Laser Notice No. 56, dated May 8, 2019.
CLASS 2 LASER PRODUCT APPARIL À LASER DE CLASSE 2.

Complies with 21 CFR 1040.10 and 1040.11 except for conformance with IEC 60825-1 Ed. 3., as described in Laser Notice No. 56, dated May 8, 2019.

MAX. 1mW:630-680nm.

LASER RADIATION

DO NOT STARE INTO BEAM

CLASS 2 LASER PRODUCT

CONSUMER LASER PRODUCT

EN 50689:2021

ASKEY TECHNOLOGY (JIANGSU) LTD., No.1388, Jiao Tong Road, Wu Jiang Economic-Technological Development Area, Jiangsu Province 215200, P.R.C. provided on the housing (enclosure) of the product, outside of the package, container, user manuals or product's directions for users per 21CFR 1010.3(1) and Laser Notice No. 53.

LED Devices

Classified as 「EXEMPT RISK GROUP」 according to IEC 62471:2006 and EN 62471:2008.

Power Supply

Use ONLY a ASKEY approved Nationally Recognized Test Laboratory (NRTL) Certified ITE (LPS/SELV) power supply with electrical ratings:

Please contact the retailer to inquire about purchasing power supplies.

Battery

Rechargeable batteries contain scarce, valuable recyclable resources. We kindly ask for your cooperation in recycling to promote reuse of these resources.



The crossed-out wheeled bin is applicable for EU member status only.

Used rechargeable batteries must not be disposed of as combustibles.

Contact your nearest battery recycling centre or local sales office for information on disposal procedures.

Never disassemble or break down rechargeable batteries.

Use only ASKEY approved batteries. Accessories which have battery charging capability are approved for use with the following battery models:

For use with RC40 Rugged Mobile Computer

For use with rechargeable lithium-ion battery pack (mfr.: FUJI ELECTRONICS (SHENZHEN) CO LTD / model: RC40-BR-SBL500 / nominal voltage: 3.85 Vdc, nominal capacity: 5000 mAh, 19.25 Wh, rated capacity: 4900 mAh, 18.865 Wh)

 CAUTION: RISK OF EXPLOSION IF BATTERY IS REPLACED BY AN INCORRECT TYPE. DISPOSE OF USED BATTERIES ACCORDING TO THE INSTRUCTIONS.

 ATTENTION : Remplacer la batterie par un type de batterie inadapté présente un risque d'explosion.

 Handling battery

Failure to follow all instructions listed below may cause electrical shock, overheating, smoking, fire, or an explosion.

- Never disassemble or modify the battery.
- Do not stick a needle into the battery, hammer at it, or tread on it.
- Avoid dropping or throwing the battery or letting it undergo any shock or impact.
- Do not use significantly damaged or deformed batteries. Do not use batteries when they are subject to the impact, for example, a drop impact.
- Never connect the positive and negative terminals of the battery with a wire or other metallic materials.
- Do not carry or store the battery together with ballpoint pens, necklaces, coins, hairpins, or anything else metallic.
- Never place the battery into or soak it in water or seawater.
- Never burn or heat up the battery.
- Do not use or leave the battery in places where there is excessively high temperature (60 °C or higher) such as near fire or heater.
- Do not use or store the battery in places exceeding the service or storage temperature.
- Never charge the battery near a fire or in strong sunlight. Raised battery temperature may result in leakage of battery fluid, blowout, or combustion.
- Never charge or use the battery where any inflammable gases may be emitted.
- Never apply solder directly to the battery.
- Do not use batteries other than the specified ones.
- If the battery fluid leaked from the battery gets into the eyes, wash thoroughly with clean water such as tap water without rubbing and obtain medical treatment immediately. Failure to do so will result in eye injuries.
- During use, charging, or storage of the battery, if odors come from the battery, the battery is overheated, discolored, deformed, or anything unusual is found, unload the battery. Do not use the battery.
- If the battery does not finish recharging within the specified time, stop recharging.

Handling the RC40

Incorrect handling of the RC40 could cause electric shock, impaired vision, skin problems, injury, burns and generation of heat and smoke from the RC40. Be sure to observe the following to use the device correctly.

- Never disassemble or modify the RC40.
- When the RC40 is subject to the strong impact, for example, a drop impact, check the case for any damage and the battery for damage and leakage.
Never use a damaged case.
Never use a damaged or leaked battery.
- Do not insert any foreign materials into the battery cartridge.
- Do not get the RC40 wet or put it in water or seawater.
- Never put the RC40 in a microwave oven or high-pressure container. Never put it on the induction cooktop.
- Never put the RC40 in places where there are excessively high temperatures, such as inside closed-up automobiles, or in places exposed to direct sunlight.
- Avoid using the RC40 in extremely humid or dusty areas, or where there are drastic temperature changes.
- If smoke, abnormal odor or noise comes from the RC40, immediately turn off the power and remove the battery cartridge from the scanner case.
- If the LCD screen is broken by mistake, care must be taken not to get the liquid crystal into your eyes or mouth or drop it on your skin.
- Be careful of broken glass if the LCD screen is accidentally cracked or broken. It may cause bodily injury.
- If the LCD screen is accidentally broken and liquid crystal gets into your eyes or mouth, wash it off immediately with clean water and then seek medical care.
- Never stare into the reading window.

Battery SAFETY INSTRUCTIONS

CAUTION: Read these instructions carefully to ensure safe operation.

Read and keep these instructions. Heed all warnings. Follow all instructions.

- 1) Do not use this apparatus near water.
- 2) Clean only with dry cloth.
- 3) Do not block any ventilation openings, install in accordance with the manufacturer's instructions.
- 4) Do not install near any heat sources such as radiators, heat registers, stoves, or other apparatus (including amplifiers) that produce heat.
- 5) Do not defeat the safety purpose of the polarized or grounding-type plug has two blades with one wider than the other. A grounding type plug has two blades and a third grounding prong. The wide blade or the third prong is provided for your safety. If the provided plug does not fit into your outlet, consult an electrician for replacement of the obsolete outlet.

- 6) Protect the power cord from being walked on or pinched particularly at plugs, convenience receptacles, and the point where they exit from the apparatus.
- 7) Only use attachments/accessories specified by the manufacturer.
- 8) Unplug this apparatus during lightning storms or when unused for long periods of time.
- 9) Refer all servicing to qualified service personnel. Servicing is required when the apparatus has been damaged in any way, such as power-supply cord or plug is damaged, liquid has been spilled or objects have fallen into the apparatus, the apparatus has been exposed to rain or moisture, does not operate normally, or has been dropped.

Safety precautions

WARNING: TO PREVENT FIRE OR ELECTRIC SHOCK, DO NOT EXPOSE THIS APPLIANCE TO RAIN OR MOISTURE.

CAUTION: TO REDUCE THE RISK OF ELECTRIC SHOCK, DO NOT REMOVE COVER (OR BACK). NO USER-SERVICEABLE PARTS INSIDE. REFER SERVICING TO QUALIFIED SERVICE PERSONNEL.

- 1) **WARNING---**To reduce the risk of fire or electric shock, do not expose this apparatus to rain or moisture.
- 2) Apparatus shall not be exposed to dripping or splashing and no objects filled with liquids, such as vases, shall be placed on the apparatus.
- 3) The apparatus shall be operated in open space.
- 4) A warning that an apparatus with CLASS 1 construction shall be connected to a MAINS socket outlet with a protective earthing connection.
- 5) For pluggable equipment, the socket-outlet shall be installed near the equipment and shall be easily accessible.
- 6) Power Supply Cord Selection: Suitable power supply cord for is 1.5-3.0 m long, rated minimum 250 V, minimum 3.5 A, Type NISPT-2 a, SPT-2, SV, SVT, SVE, SJ, SJT, SJE flexible cord. One end terminates in a parallel blade (NEMA 5-15P) grounding type attachment plug. The other end terminates in Appliance Inlet Coupler.

1.3 CUSTOMER SUPPORT

Technical Support

If you have any technical problem, please report to SupportUSA@askey.com, AIC will respond to it within 24 hrs.

Please provide the following information

- Serial number
- Date of purchase
- Model or product name (such as RC40)
- Software version if it is available
- Problem description

If we can identify that it is a hardware problem, we will ship the replacement in advance to suit your needs before receiving your faulty unit. Please ship out the faulty unit to Askey within 5 days after your report.

Customer Service

Askey International Corp has an official Webpage where you can submit enquiries or technical questions that we will give feedback to you within 5 business days. Go to Askey.com and select Contact Askey > contact us > technical Support.

1.4 PRODUCT WARRANTY

Subject to the terms of Askey's hardware warranty statement, the RC40 is warranted against defects in workmanship and materials for a period of 1 year from the date of shipment. For the complete warranty statement, please visit:

<https://www.askey.com/download/0/RC40Warranty/>

Or contact us by phone number: 1-(866)-882-7539

Any inappropriate use of this product, such as incorrect charging, ransomware install, abuse, or other behavior not following the user guide, are not covered under ASKEY warranty.

2. GETTING STARTED

2.1 INTRODUCE

Similar in styling and comfort to a smartphone. The RC40 is designed to keep your Enterprise business running at peak efficiency to outsmart your competition without having to outspend them. A pocket-friendly design conceals a rugged form factor and purpose-built features capable of meeting any size business challenge, the Askey RC40 offers an enterprise grade blend of performance and user-friendly design empowering teams to access applications, information and people to get the job done, wherever the job takes them.

The Askey RC40 handheld mobile computer features cutting-edge processing power, seamless connectivity, integrated data collection and built for your business to outlast the unconscious abuse in your enterprise, while maintaining a sleek smartphone form factor.

2.2 PRODUCTION DETAIL

OVERVIEW



RC40 Mobile Computer

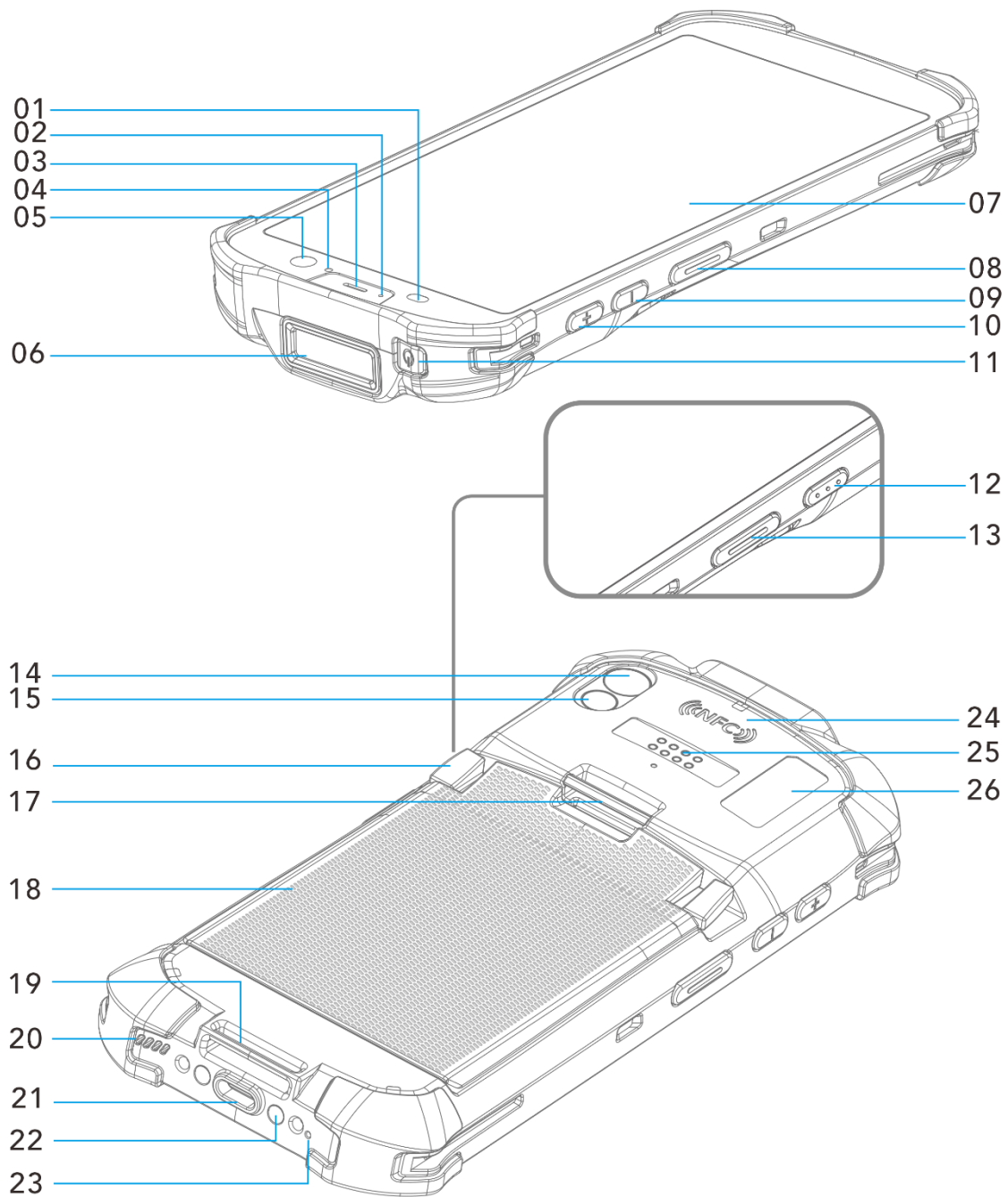

01. P-Sensor	14. Rear Camera
02. Microphone	15. Flash
03. Receiver	16. Battery release Latch
04. Notification LED	17. Hand Strap support
05. Front Camera	18. Battery
06. Scanner	19. Hand Strap Support
07. Touch Screen	20. Speaker
08. Scan key (Left)	21. USB-C port

09. Volume Down	22. Charging pins
10. Volume Up	23. Microphone
11. Power Button	24. NFC Detection Area
12. PTT Button (Programming Key)	25. I/O Connector
13. Scan key (Right)	26. Laser Safety Label

DATASHEET

HARDWARE

- DIMENSION: 169 x 78 x 14.7 (LxWxD, MM) (6.6 IN X 3.1 IN X 0.58 IN)
- WEIGHT: 299 G (10.54 OZ) W/ BATTERY
- DISPLAY SIZE: 6" FULL HD TFT-LCD, LED BACKLIT, 600 NITS
- TOUCH PANEL: CAPACITIVE CORNING GORILLA® GLASS WITH WET FINGER/GLOVE SUPPORT
- POWER: USER REMOVABLE LI-ION 5000 MAH BATTERY (18.5 WH), SUPPORT QC4.0 WITH FULLY CHARGE NEEDS LESS THAN 3 HOURS, WARM SWAP
- I/O PORTS:
TYPE C USB 3.1/USB QC4.0
2 PIN CHARGING PAD
8 PIN EXPANSION PORT
1 NANO SIM, 1 eSIM
1 USER ACCESSIBLE MICROSD CARD SLOT SUPPORTS UP TO 1 TB
- NOTIFICATIONS:
AUDIBLE TONE
MULTI-COLOR LEDs
VIBRATION
- AUDIO:
TWO MICROPHONES WITH NOISE CANCELLATION
BLUETOOTH WIRELESS HEADSET SUPPORT
HIGH QUALITY SPEAKER PHONE
PTT USB-C HEADSET SUPPORT
HD VOICE, INCLUDING SUPER-WIDEBAND (SWB), WIDEBAND (WB) AND FULLBAND (FB)
VOLTE AND VONR SUPPORT
- BUTTONS:
DUAL DEDICATED SCAN BUTTONS
PROGRAMMABLE BUTTON FOR PTT OR OTHER USE

VOLUME UP/DOWN

POWER

SYSTEM

- CPU: QUALCOMM® QCM4490 KRYO™ OCTA-CORE PROCESSOR @2.4GHZ
- OPERATING SYSTEM: UPGRADABLE THROUGH ANDROID® 18
- MEMORY: 8 GB DDR4x RAM/128 GB UFS FLASH

ENVIRONMENTAL

- OPERATING TEMPERATURE: -20°C ~ +50°C / -4°F ~ +122°F
- STORAGE TEMPERATURE: -40°C ~ +60°C / -40°F ~ +140°F
- HUMIDITY: 5% TO 95% (NON-CONDENSING)
- DROP: MULTIPLE 6 FT./1.8 M DROPS TO CONCRETE PER MIL-STD-810H
- SEALING: IP68 AND IP65, WITH BATTERY PER APPLICABLE IEC 60529
- TUMBLE: 1000 TUMBLES, 1.6 FT./0.5 M
- ELECTROSTATIC DISCHARGE: +/- 15kVDC (AIR) / +/- 8KV (CONTACT)

SENSORS

- AMBIENT LIGHT: DYNAMICALLY ADJUSTS DISPLAY BACKLIGHT BRIGHTNESS
- PROXIMITY: DETECT WHEN THE USER PLACES THE HANDSET AGAINST HEAD DURING A PHONE CALL TO DISABLE DISPLAY OUTPUT AND TOUCH INPUT
- MOTION: 3-AXIS ACCELEROMETER WITH MEMS GYRO
- MAGNETOMETER: E-COMPASS FOR DIRECTION AND ORIENTATION DETECTION
- BAROMETER: PRESSURE SENSOR FOR ALTITUDE LOCATING

DATA CAPTURE

- SCANNING: HONEYWELL N5703SR /N6803LR
- CAMERAS:
REAR CAMERA 16 MP
FRONT CAMERA 8 MP
- NFC:
ISO 14443 TYPE A AND B

SONY FELICA11
ISO 15693 CARD

CERTIFIED APPLICATION

- GMS/AER
- SCALEFUSION CERTIFIED ([HTTPS://SCALEFUSION.COM/](https://scalefusion.com/))
- STAYLINKED READY™ ([HTTPS://WWW.STAYLINKED.COM/](https://www.staylinked.com/))

WIRELESS CONNECTIVITY

- WAN:
CERTIFIED: GCF-PTCRB
5G SUB 6GHZ:
N1, N2, N3, N5, N7, N8, N12, N13, N14, N18, N20, N25, N26, N28, N29, N30, N38, N40, N41, N48, N53, N66, N70, N71, N77, N78, N79
4G LTE:
BANDS 1, 2, 3, 4, 5, 7, 8, 12, 13, 14, 17, 18, 19, 20, 25, 26, 28, 29, 30, 32, 38, 39, 40, 41, 42, 43, 48, 53, 66, 70, 71
WCDMA:
BANDS 1,2,4,5,8,1
PRIVATE NETWORK: SUPPORTS PRIVATE NETWORKING (LTE/5G), CBRS
US (N48/B48)/JP(B42)/EU (N77/N78)
- GPS: SUPPORT, GPS, GLONASS, QZSS, BEIDOU AND GALILEO (A-GPS)
- WLAN:
IEEE 802.11 A/B/G/N/AC/D/H/I/R/K/V/W/MC/AX
2x2 MU-MIMO
WI-FI™ 6E CERTIFIED
IPV4, IPV6
- WLAN SECURITY:
ENCRYPTION: OPEN, ENHANCED OPEN, WEP (40/128), TKIP AND AES
WPA AUTHENTICATION: WPA AND WPA2 AND WPA3
USER AUTHENTICATION: PSK, EAP-TLS, AND PEAP
- WPAN/BLUETOOTH®: BLUETOOTH® 5.2, BLE 5, CLASS 2

2.3 PACKAGE CONTENT

- RC40 Mobile Computer
- Standard Battery (5000 mAh)

- Quick Start Guide

2.4 ACCESSORY (AVAILABLE FOR PURCHASE)

- Single Communication and Charge Cradle
- Scan Handle
- Hand Strap
- Wrist Strap
- 3rd party rugged mobile mounts; see RC40 Accessory Guide (https://www.askey.com/download/0/RC40_Accessory_Guide/)

2.5 INSTALLATION

2.5.1 INSTALL/REMOVE BATTERY

CAUTION: Do not place any labels, asset tags, engravings, stickers, or other objects into the battery well. Doing so may affect the intended performance of the device or accessories. Performance levels such as water resistance, impact resistance, functionality or temperature resistance may be affected.

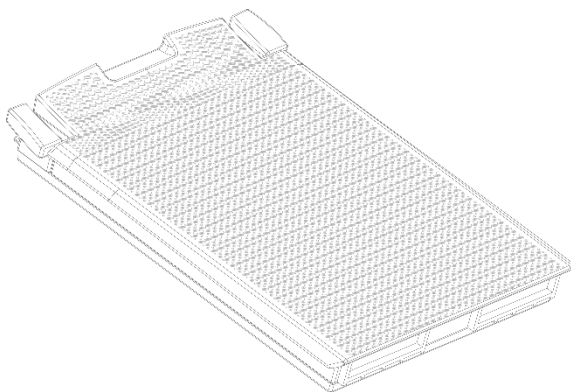

Install Battery: Put Battery pack at bottom to align and press the battery downward until the latches on both sides of the battery into place.

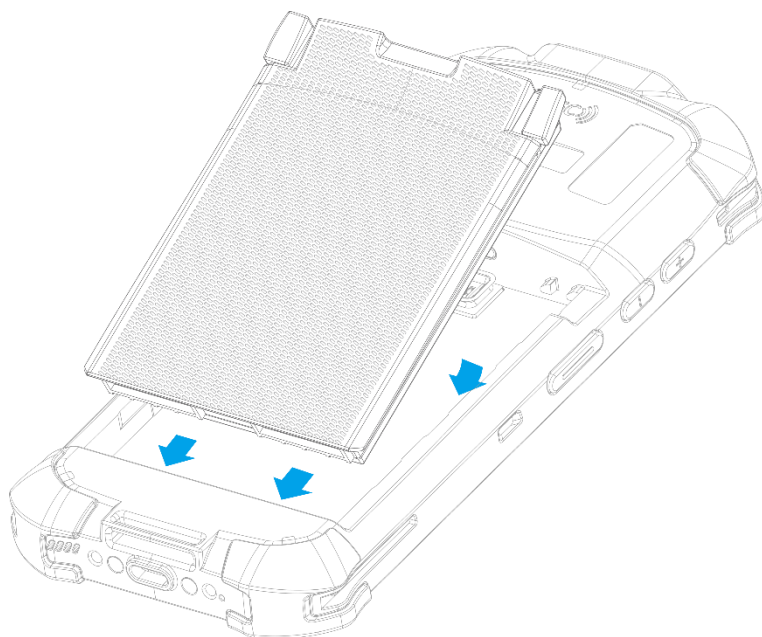

Remove battery: Push latch at both sides together and pull battery from the mobile computer

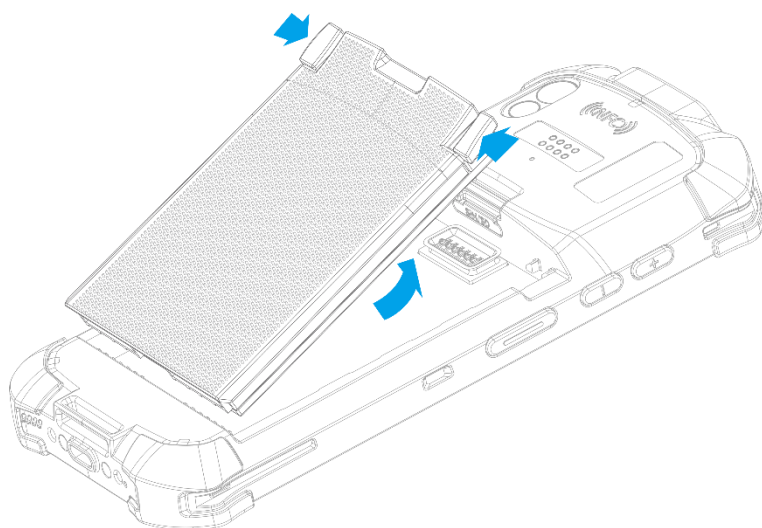

Important Notice: Any user modifications to the device, especially within the battery well—including labels, asset tags, engravings, or stickers—may negatively impact the device’s performance and the functionality of its accessories. Such modifications can affect critical performance factors, including sealing integrity (Ingress Protection [IP]), impact resistance (drop and tumble), overall functionality, and temperature tolerance. To ensure optimal performance and durability, **do not apply labels, asset tags, engravings, or stickers within the battery well.**

Caution—ESD: Observe proper Electrostatic Discharge (ESD) precautions to avoid damage to the SIM/Micro SD card.
Proper ESD precautions include, but are not limited to, working on an ESD mat and ensuring the operator is properly grounded.

1. Remove the SIM/SD tray from the device.

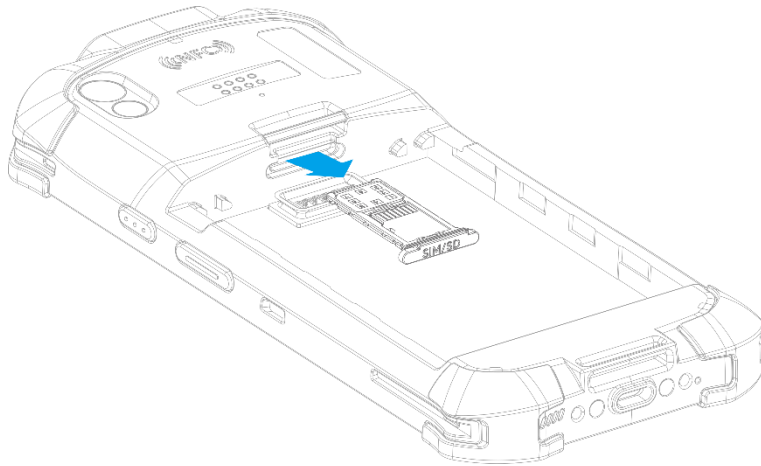

2. Put the SIM/micro SD card on the tray, and make sure the SIM/micro SD cards are firmly stuck on the tray.

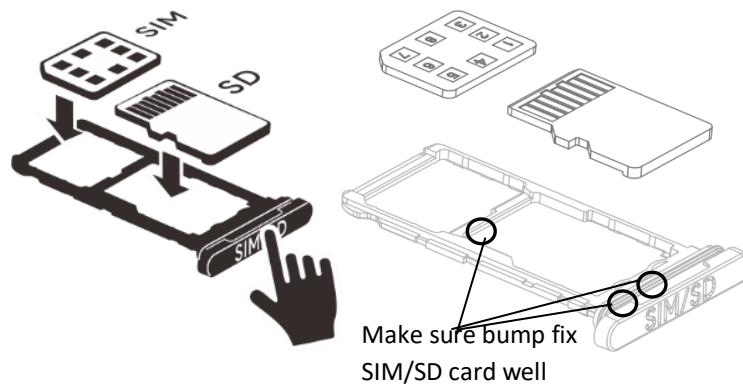

3. Install the SIM/SD tray into the device with the correct direction.
NOTE, when you insert the card tray into the device, the SIM/micro SD card pins should be on the upper side of the tray.

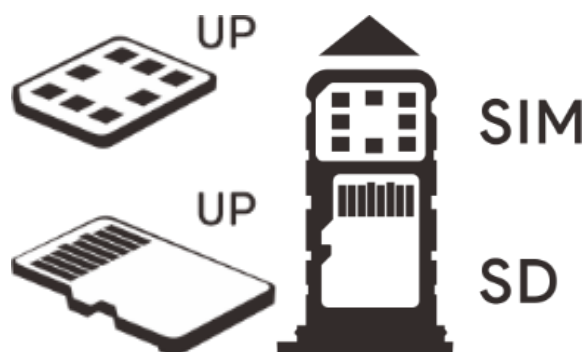

4. Push the tray back into device

Note: The SIM/SD tray needs to be pushed to the bottom and the SIM/SD cover cannot be in the middle to ensure waterproof function.

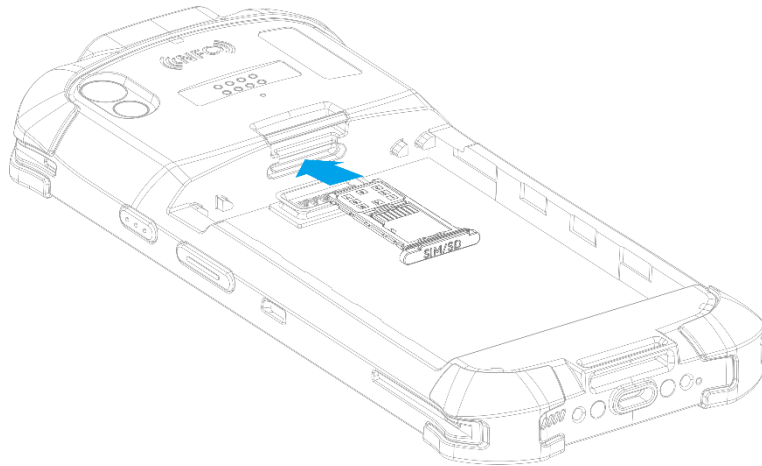

2.5.3 CHARGING CRADLE

To charge the mobile device battery, the battery and charger temperatures must be between +41°F and +104°F (5°C and +40°C).

- Need to use Askey power supply attach in the box
Using an incompatible power supply may damage cradle and mobile computer, and lead to the dangers of fire, explosion, or other risks.
If you have any questions about the compatibility of power supply, please contact Askey support, <https://www.askey.com/support/>
- Do not use incompatible batteries, cradles, and mobile computers.
Using an incompatible battery, cradle, or mobile computer may damage battery, cradle, or mobile computer, and lead to a danger of fire, explosion, or other risks.
If you have any questions about the compatibility of power supply, please contact Askey support, <https://www.askey.com/support/>
- Warning: The USB IO at the rear side of the cradle is for data communication, please don't INSERT USB-C power supply to avoid the damage or explosion risk.

Instruction manual for switching power supply

1. Model/Rating:

- A. Product name: SWITCHING ADAPTER
- B. Rated input voltage: 100-240V

C. Voltage adjustment rate: +10%, -10%

D. Rated input current: 1.0A Max.

E. Rated input frequency: 50-60Hz

F. Altitude: 5000m Max

2. Safety precautions

A. Please read the following notes carefully.

B. The maximum ambient temperature used for this product is 40°C.

C. Please set this product according to the specification.

D. Output; Please refer to the label on the product

E. This product is used in information and communication technology equipment or audio/video equipment

F. This product is fixed for use in the house.

G. If there is any fault or part damage of this product, please do not repair it personally.

H. In order not to have the danger of electricity leakage, this product please do not contact with rain water

3. Important safety matters

A. Please read the notes carefully

B. Please keep this note well. Please pay attention to the dangerous matters

C. Please use this product according to the specification

D. Please be sure to use this product near water

E. Please clean with a dry cloth.

F. Do not use this product in radiators, stoves, or other places that contain heating devices.

G. Please unplug the power when it thunders or is not used for a long time.

H. In case of failure, please contact the after-sale service personnel. When the plug is damaged, the product is immersed in water, when the product falls to the ground and is touched by rain, or when the product is in abnormal operation, please contact the after-sale service personnel.

I. This product is a class I device.

◆ Mobile device connection:

Insert the L-shaped output end of the transformer into the charging dock.

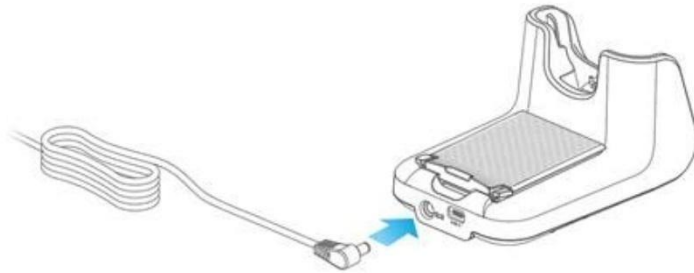

When the power light on the left side of the charging dock turns green, insert the mobile device with the screen facing forward into the charging dock.

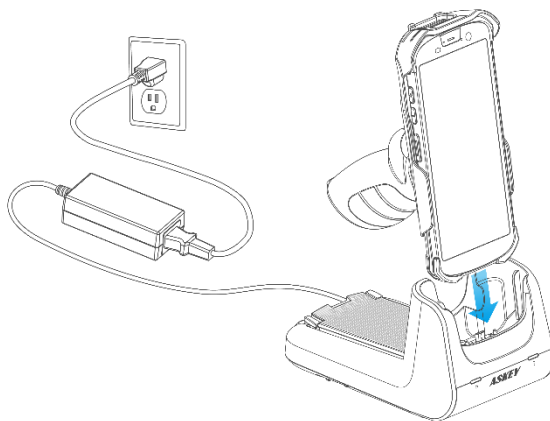

When the power light on the left side turns amber, the mobile device is successfully connected.

Mobile Device Removal:

Press down the charging dock with one hand and hold the mobile device with the other hand to pull it up. After pulling it up, the power light will turn from amber to green, indicating that the mobile device has been successfully removed.

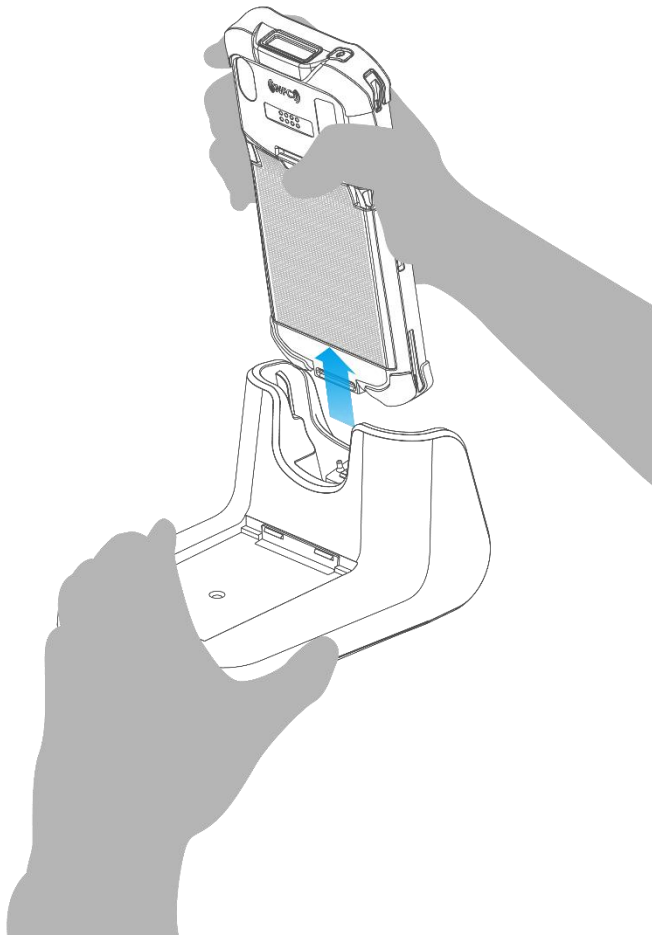

Battery Charging:

Align the bottom of the battery with the inside of the charging station, and then press the battery down to complete the placement.

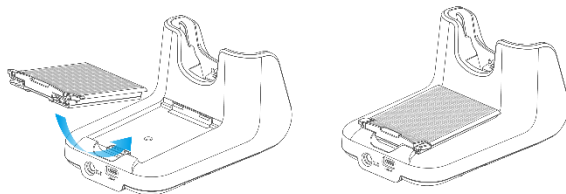

At this time, the LED light on the right side of the charging station will light up. The light signal description is shown in the following table.

*When the battery is over 4.15V and the temperature is above 45°C, the red light will flash when it is placed in the charging station for charging. This is because the charger has activated the battery high temperature overvoltage protection mode, which is a normal phenomenon.

* When the battery is charged at an ambient temperature higher than 35°C, the amber light and red light may flash alternately. This is because the battery charger is regulating the temperature of the charged battery and activating the battery high temperature overvoltage protection mode. This is a normal phenomenon.

* If you need to fully charge the battery within three hours, please make sure the product is at room temperature of 25°C, placed in a well-ventilated location (battery temperatures above 45°C and below 10°C will extend the charging time)

* The temperature detection chip and components have tolerance about +/-3°C, so it is normal that the spare battery may not be charged while the operating temperature is -3~3°C (the battery charging LED on the charging station flashes red).

Battery Removal:

Press the charging dock with one hand and press the latches on both sides of the battery with the other hand. Lift the battery to remove the battery.

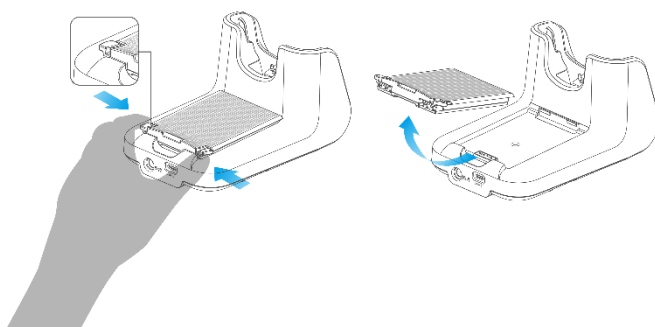

LED Indicator	Behavior	Status
Terminal & Power	Solid Amber	Terminal connected
	Solid Green	No terminal connected
	No Color	No power
Battery	Solid Amber	Charging, the capacity is less than 95%

	Solid Green	Charging, the capacity is higher than 95% or equal to 95%
	Blink Red	Charge error
	No Color	No battery inserted

Cradle series connection

Push the bracket and insert the boss on another cradle into the hole in the batch to connect cradles. (Each cradle requires its own power supply)

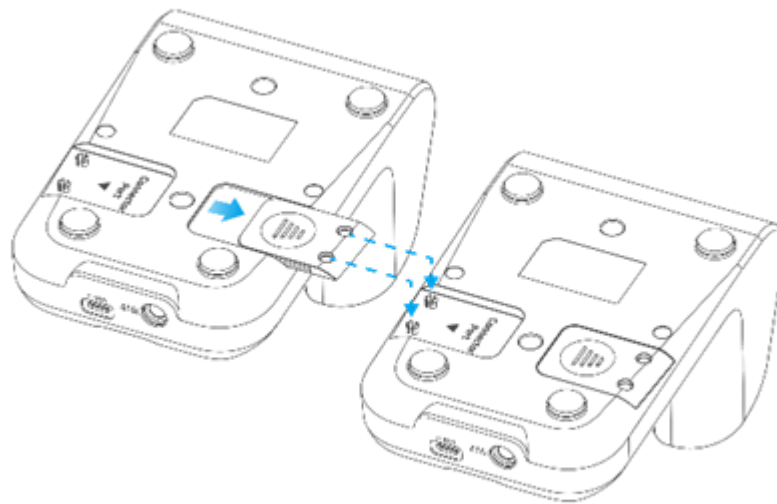

2.5.4 USB CHARGER

Connect the Type C charging cable to the charger and mobile device to charge

*Using a charger with lower output power may result in charging failure or prolonged charging time.

*If you need to fully charge the battery within three hours, please make sure the product is at room temperature of 25°C, not in operation and placed in a well-ventilated location (battery temperatures above 45°C and below 15°C will extend the charging time)

*If the battery temperature is above 45°C, the charging indicator may turn green even though the battery charge is less than 90%. This is a reasonable behavior of the system based on the battery charging temperature protection mode. Please do not worry.

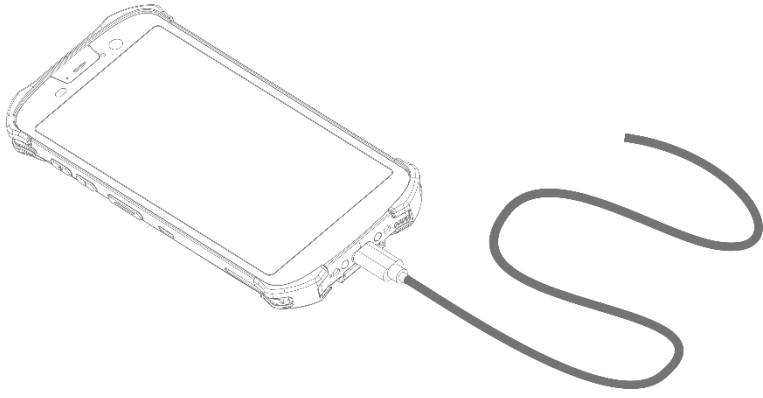

3. BASIC OPERATION

3.1 POWER ON/OFF THE DEVICE

Power on: Press power button on top of device for 3 seconds

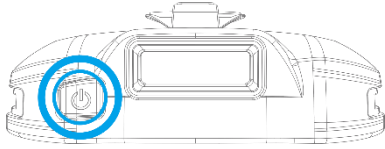

Power off:

Step 1. Press power button + Volume up button to show power menu

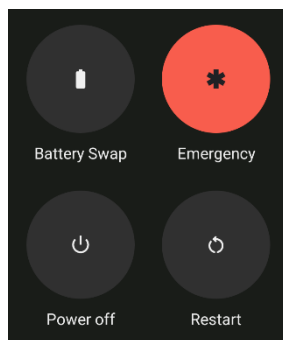

Step 2. Press Power off button and wait for the device shut down

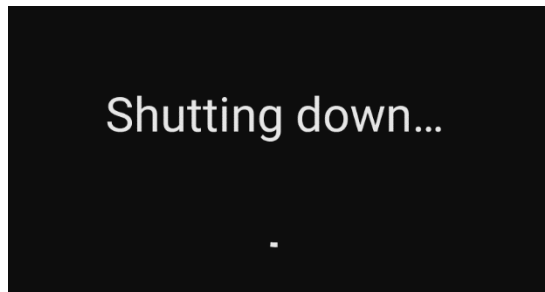

3.2 WELCOME

The LCD will show Askey animation below



3.3 BATTERY

3.3.1 MAIN BATTERY

The main battery uses a rechargeable and user removable 3.85V, 5000mAh (18.5 WH) lithium battery pack to power the mobile data terminal, and it takes about 3 hours to fully charge. The LED light above the screen will light up red while charging, and turn green when the power reaches 90% or more.

3.3.2 BACKUP BATTERY

The backup battery is a rechargeable lithium battery mounted on the motherboard and is used to maintain the mobile computer during battery replacement, ensuring data retention for 1 minute when the battery is fully charged and the wireless module is inactive.

The backup battery can be charged from the main battery and a full charge takes about 1 hour and 30 minutes.

3.3.3 BATTERY STATUS

The battery status can be checked by the battery icon on the upper right of the screen to check the capacity and whether it is charging.

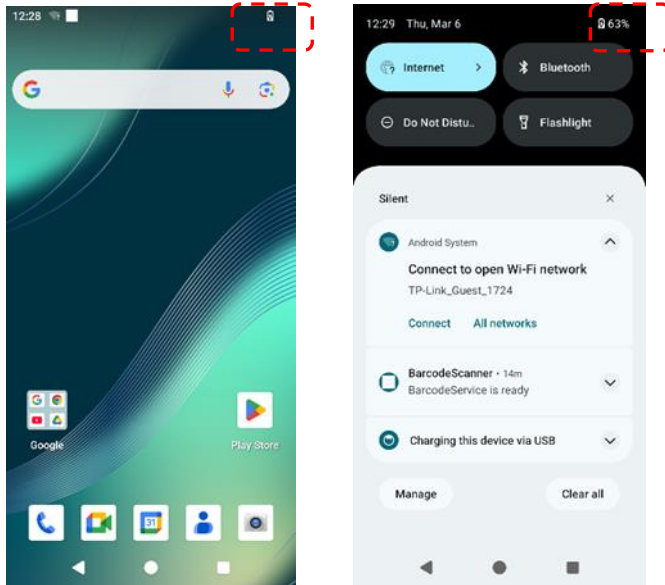

Battery Icon	Description
	Main battery is fully charged.
	Main battery is partially drained.
	Main battery level is low (=< 15%).
	External power source is connected and main battery is being charged.

3.3.4 LOW BATTERY ALERT

When the battery level is below 15% and 10%, a warning will be given and it will indicate whether to enter power saving mode.

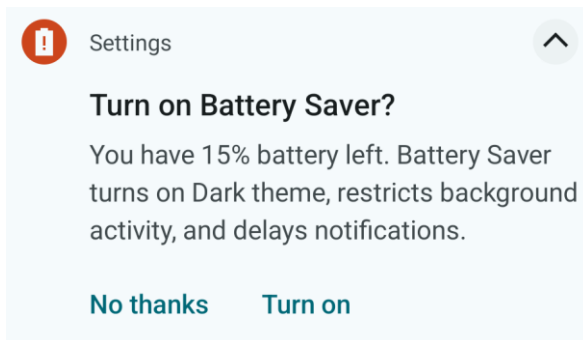

3.3.5 MAIN BATTERY SWAP

3.3.5.1 COLD SWAP

Step 1. Press power button + Volume up button to show power menu

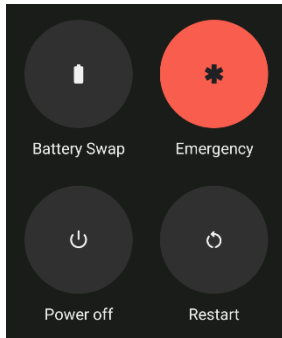

Step 2. Press Power off button and wait for the device shut down

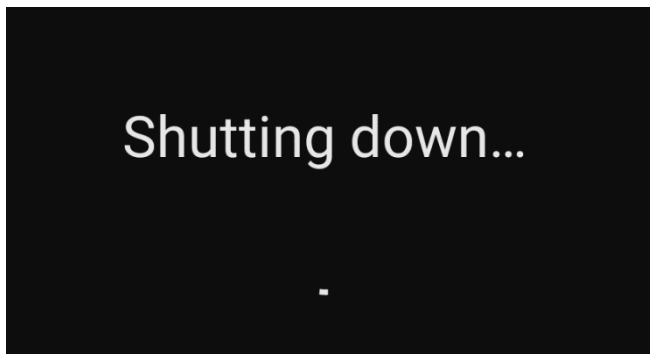

Step 3. Exchange Battery (Can find detail in sec 2.5.1)

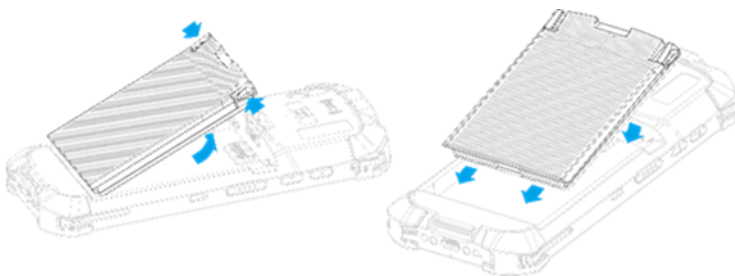

3.3.5.2 WARM SWAP

Step 1. Press power button + Volume up button to show power menu

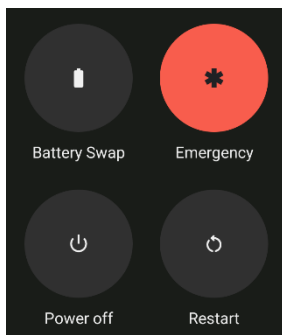

Step 2. Press Battery Swap button

Step 3. Wait for the flashing red light to be off

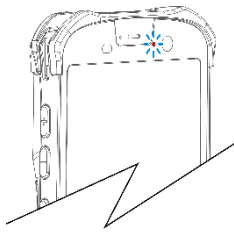

Step 4. Exchange Battery (Can find detail in sec 2.5.1)

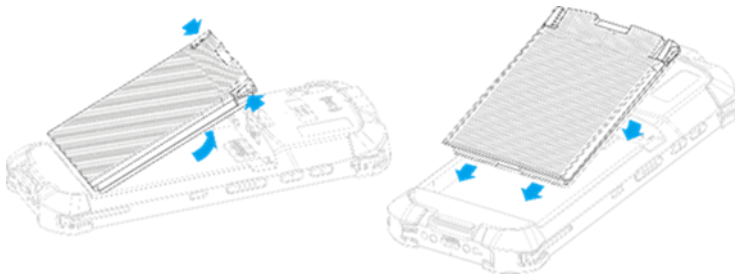

Step 5. You can press the power button or connect the USB power supply to wake up the system, no matter if you replace the main battery or not.

⚠ To avoid system damage, do not connect a charging device or USB device when the main battery is disconnected.

3.3.6 BATTERY OVERHEAT PROTECTION

When the battery temperature is too high or too low, the system will provide a warning, above 62°C or below -19°C

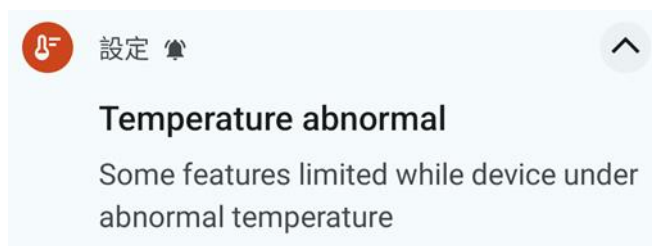

⚠ If the temperature continues to rise or drop beyond the warning value, the machine will be shut down, above 65°C or below -22°C

Shutting down...

3.3.7 BATTERY MANAGEMENT

3.3.7.1 BATTERY USAGE

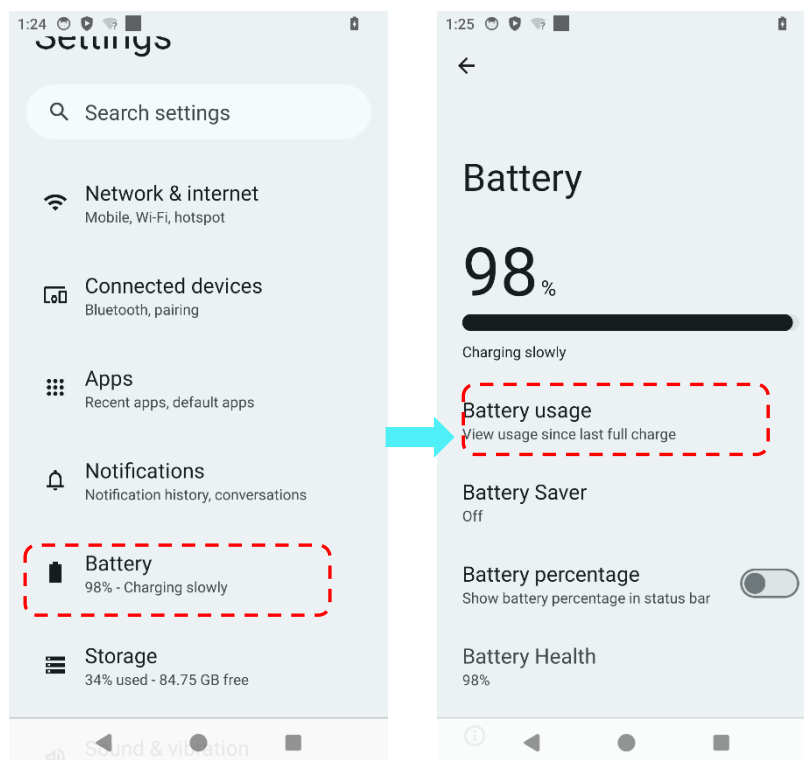

3.3.7.2 STAMINA MODE

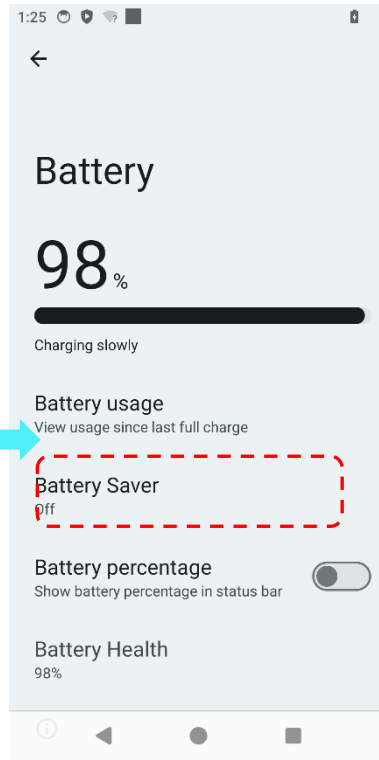
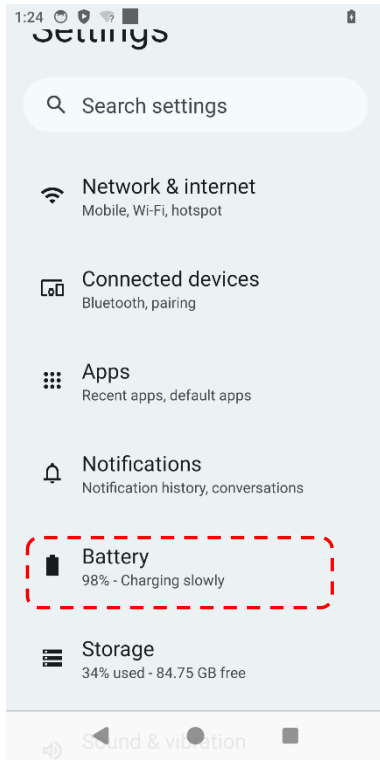

3.3.7.3 BATTERY CARE

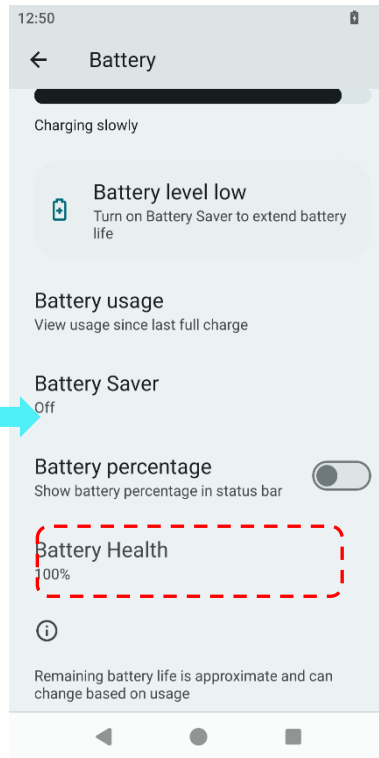
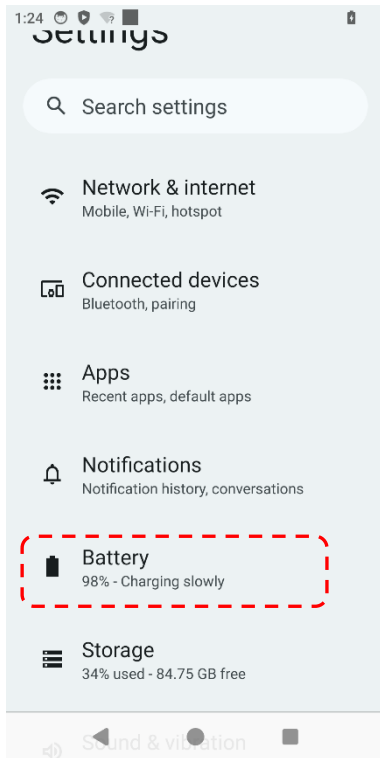

3.3.7.4 BATTERY PERCENTAGE

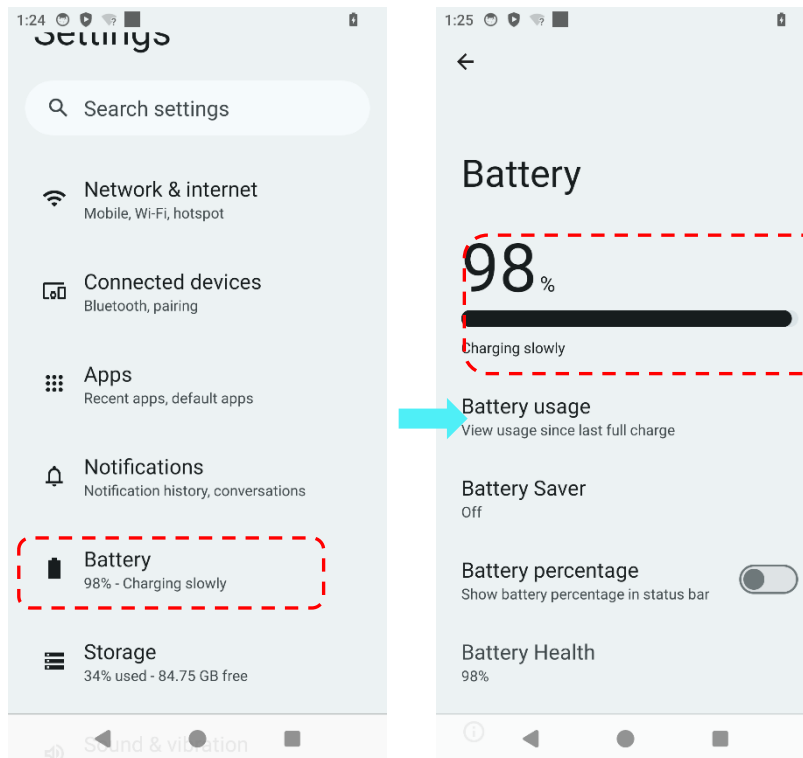

3.4 MEMORY

- Flash memory

The 128GB UFS flash memory can be stored not only Android 14 OS, but also the legitimate application in Google play and your own customized program

- RAM

The 8GB DDR4x SDRAM provide you higher clock rate and data rate with lower power consumption and higher reliability, when system operating

- Expansion Slot

RC40 offer you a single SD card slot, which is compatible with SD (up to 2GB), SDHC (up to 32GB)

Suggest to format SD card when you use a new SD card in RC40

DATA LOSS WARNING

Once main battery power is drained or main battery is removed (please refer to 3.2.5 MAIN BATTERY SWAP), the backup battery can preserve data for 1 minute, when backup battery power is also drained, RC40 will shutdown, and all unsaved data will be lost.

Please pay attention to saving your data all the time to avoid any urgent situation, such as power being drained, accident, etc.

3.4.1 STORAGE MANAGEMENT

Monitor Storage Usage: Get a clear overview of the device's internal storage, including the total capacity and how much is currently being used. This is displayed numerically (e.g., "44 GB used of 128 GB total") and visually with a bar graph.

Storage manager: An automated feature (toggleable) that likely suggests or performs actions to optimize storage.

Free up space: Directly launching the Files by Google app (or a similar file management app) to manually browse and delete files.

Trash: Shows the amount of storage currently occupied by deleted files in the system's trash or recycle bin. Tapping this usually allows viewing and permanently deleting these files.

System: Displays the storage space used by the Android operating system and pre-installed system applications. This is generally not user-manageable.

Documents & other: Shows the storage consumed by documents, downloaded files, and other uncategorized files. Tapping this allows browsing and managing these files.

Games: Indicates the storage space used by installed games. Tapping this would likely show a list of installed games with options to manage their storage or uninstall them.

Apps: Displays the storage used by all installed user applications (excluding system apps). Tapping this leads to a list of apps where you can view individual app storage, clear cache/data, or uninstall them.

Audio: Shows the storage occupied by music files, podcasts, and other audio content. Tapping this would likely open a media management app or allow browsing audio files.

Videos: Indicates the storage space used by video files stored on the device. Tapping this would likely open a video player or file manager showing videos.

Images: Displays the storage consumed by photos and other image files. Tapping this would typically open the Gallery or Photos app.

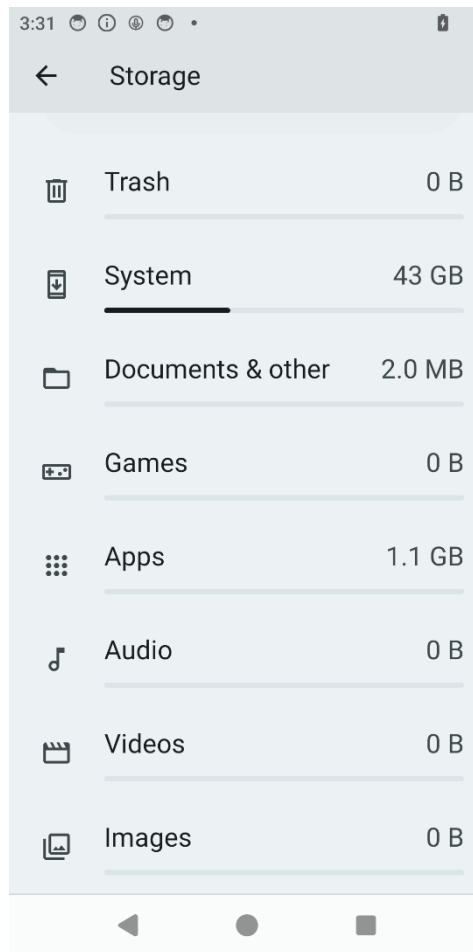
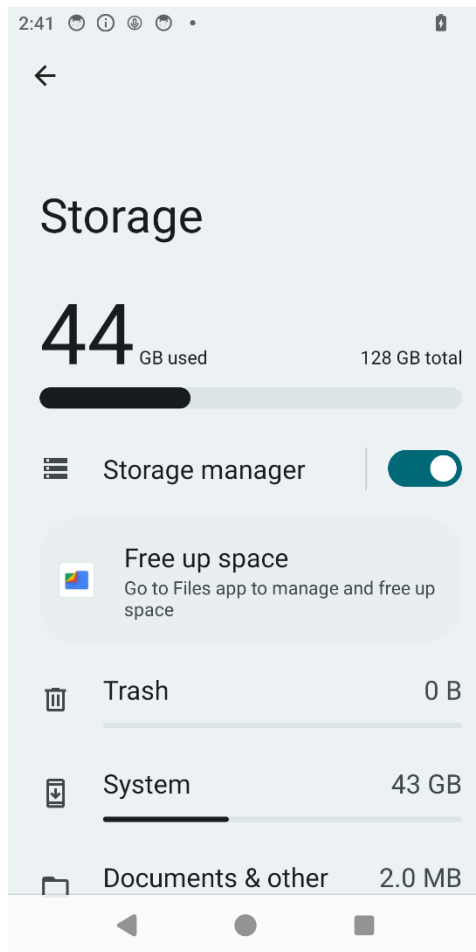

3.4.2 DATA TRANSFERRING

Android device memory data transfer include:

1. **USB Transfer:** Connecting the Android device to a computer via a USB cable allows users to directly access the device's file system (MTP - Media Transfer Protocol or PTP - Picture Transfer Protocol) and copy files back and forth
2. **Cloud Storage:** Services like Google Drive, Dropbox, OneDrive, and others enable users to upload files from their Android device to the cloud and then access or download them on other devices, and vice versa.
3. **SD Card:** Users can transfer files to and from the SD card using a computer or another device with an SD card reader. They can also move the SD card between Android devices.
4. **Bluetooth:** Suitable for transferring smaller files between nearby devices.
5. **Wi-Fi Direct:** Allows direct wireless connections between devices for faster file transfer without needing a Wi-Fi network.

6. NFC (Near Field Communication): Can be used to initiate Bluetooth or Wi-Fi Direct transfers with a simple tap between devices.
7. Google Backup: Android's built-in backup service can store app data, system settings, contacts, photos, and more in the cloud, allowing users to restore this data to a new or reset device

3.5 PHONE

3.5.1 PHONE APPLICATION

Phone applications are software designed specifically for voice calls, video calls, and other communication-related functions.

They include basic features for making and receiving calls, as well as advanced features like contact management, voicemail, call log inquiries, and call filtering.

1. Making and Receiving Calls: Provide basic calling functions, supporting both local and international calls.
2. Contact Management: Allow users to add, edit, and delete contacts, with options for grouping or tagging.
3. Call Logs: Store all call histories, including date, time, and call duration.
4. Voicemail: Record voice messages for missed calls, enabling users to respond conveniently.
5. Other Features:
 - Call filtering (blocking spam calls).
 - Support for group calls.
 - Data analytics, such as call time and cost analysis.
 - Integration with other applications, such as address books or calendars.

3.5.2 CONTACT ADD

Contact management is a feature that helps users organize and manage contact information effectively, commonly found in phone applications and mobile devices.

The following are the main features and characteristics of contact management:

1. Adding and Editing Contacts
 - Add, edit, or delete contacts.

- Store basic contact information.
2. Grouping and Tagging
 - Group contacts, such as family, friends, or work-related contacts.
 - Use tags for quick identification.
 3. Searching and Sorting
 - Sort contacts alphabetically or by recent use.
 - Support keyword searches to find specific contacts.
 4. Syncing and Backup
 - Sync the contact list to cloud services (e.g., Google or iCloud).
 5. Speed Dial and Favorites
 - Set up a speed dial for frequently used contacts to save time.

3.5.3 DURING CALLING

Refers to the features that users can operate or manage while engaging in phone or video calls.

1. Mute Function: Temporarily turns off the microphone to avoid background noise disrupting the conversation.
2. Dial Pad Operation: Allows users to input numbers during a call, such as interacting with customer service.
3. Speaker Mode: Switches to speaker mode for hands-free operation.
4. Call Hold: Pauses the call and resumes it later, making it convenient to handle other tasks.
5. Group Call: Adds more participants to the call for multi-party conversations.
6. Video Toggle: Enables users to freely turn the camera on or off during video calls.
7. End Call: Disconnects the call.

3.5.4 INCOMING CALL

When a call is received, the device displays and manages features related to incoming calls.

Here are the characteristics of incoming call functions:

1. Caller Display

- Shows the caller's name, phone number, or caller location.
- If the contact is not saved, it may display "Unknown Caller" or provide call number information.

2. Notification Alerts

- Alerts users to incoming calls via ringtone, vibration, or screen pop-up notifications.

3. Answering or Rejecting Calls

4. Call Filtering

- Uses a blacklist function to prevent calls from specific numbers.

5. Voicemail

- Provides a voicemail prompt for missed calls.

6. Group Calls

3.5.5 RECENTS

Refers to the call log feature on devices, displaying a list of calls that users have recently received, made, or missed.

1. Call Classification

- Categorizes calls into received calls, outgoing calls, and missed calls, allowing users to quickly identify them.

2. Detailed Information

- Includes the caller's name, phone number, call date and time, as well as call duration.

3. Quick Actions

- Users can directly redial, send messages, or add the number to contacts from the recent calls list.

4. Filtering and Sorting

- Allows sorting by time, with the most recent calls appearing at the top of the list.

3.5.6 CALL SETTINGS

Part of the user's customization and management of phone functionalities:

1. Notification and Ringtone Selection
 - Customize ringtones for incoming calls.
 - Set vibration or silent modes.
2. Voicemail Configuration
 - Configure voicemail notifications and storage options.
 - Customize voicemail greetings.
3. Call Filtering and Blocking
 - Manage the blacklist.
4. Call Audio Adjustment
5. Speed Dial and Shortcuts
 - Set speed dial keys for quickly contacting frequent callers.
6. Roaming and International Call Settings
 - Enable or disable roaming services.

3.6 DISPLAY

Android 14 provides an intuitive display interface that allows users to easily operate and customize display settings such as screen brightness, font size, dark mode, etc. Users can adjust these options through "Settings > Display".

3.6.1 HOME

The Android home screen is a collection point for applications and widgets. Users can adjust the arrangement of icons by dragging them, or put frequently used applications into the "Favorites Toolbar" for quick access.

3.6.1.1 NOTIFICATION / STATUS BAR

The Notification Bar and Status Bar are located at the top of the screen, providing real-time notifications, system status (such as Wi-Fi, battery level, time, etc.) and quick settings. Swipe down to view notification details, and click notification to open the app settings.

3.6.1.2 HOME SCREEN PANEL

The Home Screen Panel supports multiple pages, and users can switch between different Home Screen pages by swiping left and right. Application icons or widgets can be placed on different pages to make operation more convenient.

3.6.1.3 FAVORITES TRAY

The Favorites Tray is located at the bottom of the main screen. Users can drag the most frequently used applications to this area for quick access. This area is usually fixed and remains visible even when switching Home screen pages.

3.6.1.4 APPLICATION ICON

Application icons represent installed applications. Click them to open the applications. Long press on an icon to perform additional actions, such as removing the icon, viewing app information, or adding a widget.

3.6.1.5 GOOGLE SEARCH BAR

The Google Search Bar is located at the top of the Home screen and can be used to quickly search for content on the web, in apps, or on your device. Users can directly enter keywords or click the voice search button to perform voice input.

3.6.1.6 NAVIGATION ICON

Android provides three types of navigation icons:

Back button: Return to the previous screen or close the application.

Home button: Return to the home screen.

Recent Apps button: Opens a list of recently used apps for quick switching between apps.

The device supports gesture navigation, which replaces these buttons with swipe gestures.

3.6.1.7 FLOATING ACTION BUTTON

The Floating Action Button provides quick actions in some apps, such as:

Volume keys: Adjust the device volume.

Scan Key: Activates the scanning function (depending on the application).

Power Key: Long press to open the power menu, including options such as shutdown and restart.

The location and functionality of these buttons may vary between apps.

3.6.2 TOUCH PANEL CONTROL

Basic touch screen controls. Operations may vary depending on the program.

Single click: Touch the screen and then release it to select an item or button on the screen.

Slide: Place your finger on the screen and move it to scroll the screen.

Long press: Touch the screen and hold it to call a menu or execute a specific function

3.6.3 LOCK AND UNLOCK SCREEN

Android provides several ways to lock and unlock the screen:

Lock screen:

Press the Power button to quickly lock the screen.

You can set the auto-lock time. When the device is idle for a specified period of time, the screen will automatically lock. Can refer to section 4.1.2.2

Unlock screen:

Press the Power button or tap the screen (supported by some models) to wake up the device.

Unlock your device using Slide to unlock, Pattern unlock, PIN code or Password.

Users can choose the appropriate unlock method through "Settings > Security and Privacy > Screen Lock". section 4.1.2.1

3.7 DATA CAPTURE

ABOUT THE SCAN ENGINE

RC40 offers two Honeywell high-performance scan engine:

- Honeywell N5703 – Red laser aimer, white illumination, ideal for scanning bar codes in hand
- Honeywell N6803LR – Red laser aimer dot, white illumination, designed to read bar codes working ranges up to 25 meters [80 ft] – depending upon bar code type, condition, lighting and scan angle

3.7.1 EZWEDGE

3.7.1.1 MAIN FUNCTION

When launching the EZWedge, the main UI presents the scanned data and its detailed information.

There are

Data: Decoded data content.

Length: Decoded data length.

AimID: It's defined by the Association for Automatic Identification and Mobility (AIM).

CodeID: It can be standardized or manufacturer-specific.

CodeType: What barcode type be scanned.

Intent result: The scanned data was carried on intent to broadcast out to the application that registered the corresponding intent action.

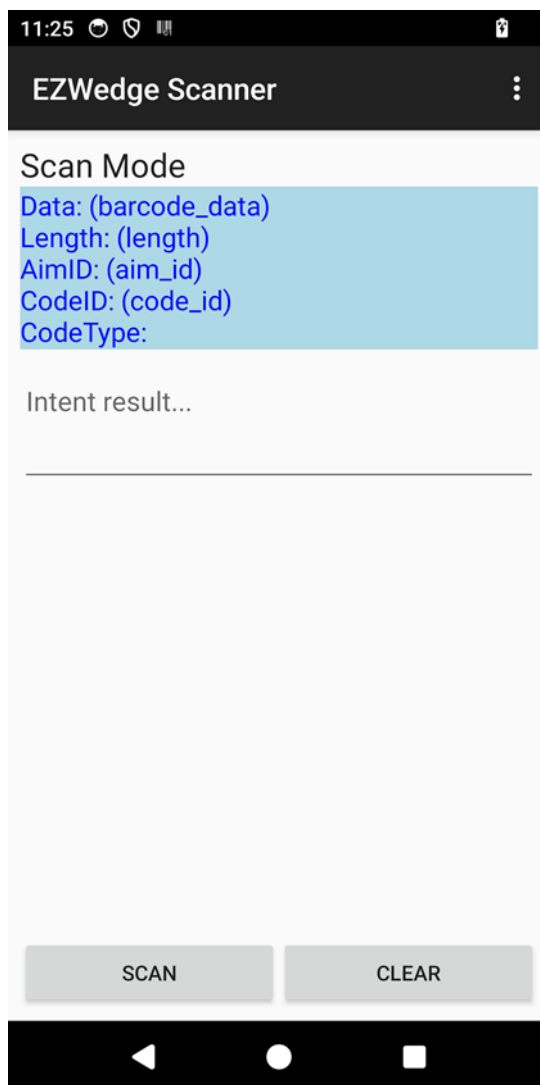

3.7.1.2 MENU FUNCTION

There are four options in the menu:

1. Get Last Image: Get the last scan image.
2. Profiles: Profiles store a specified configuration for application.
3. Settings: That contains Symbology, Decoder, Scanning and Application settings.
4. About: Present the decoder engine detail information.

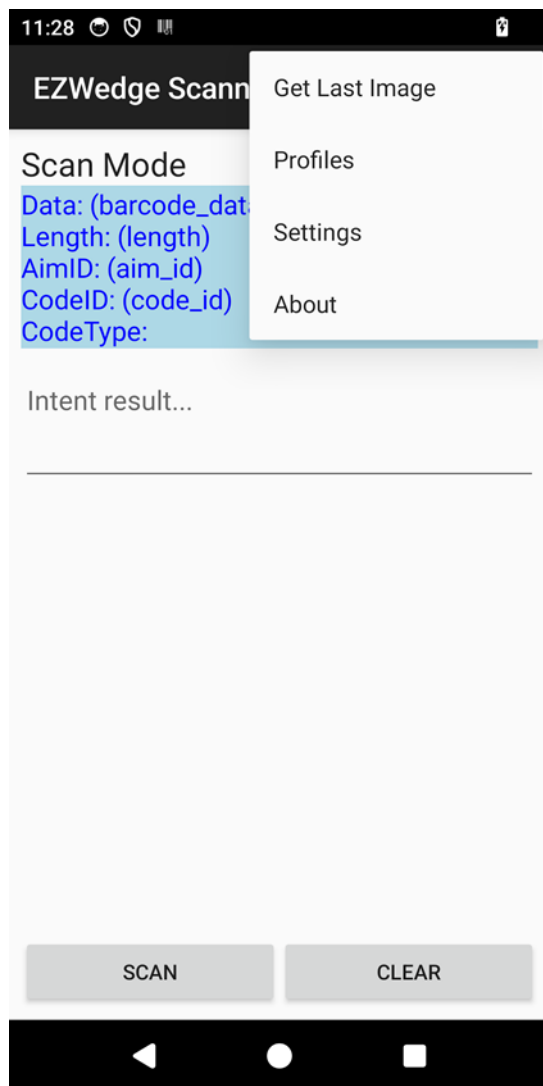

3.7.1.3 GET LAST IMAGE FUNCTION

When scanning a barcode target successfully, click the "Get Last Image" option to show up the image and click the "SAVE IMAGE" button to save it to *storage/emulated/0/Pictures*.

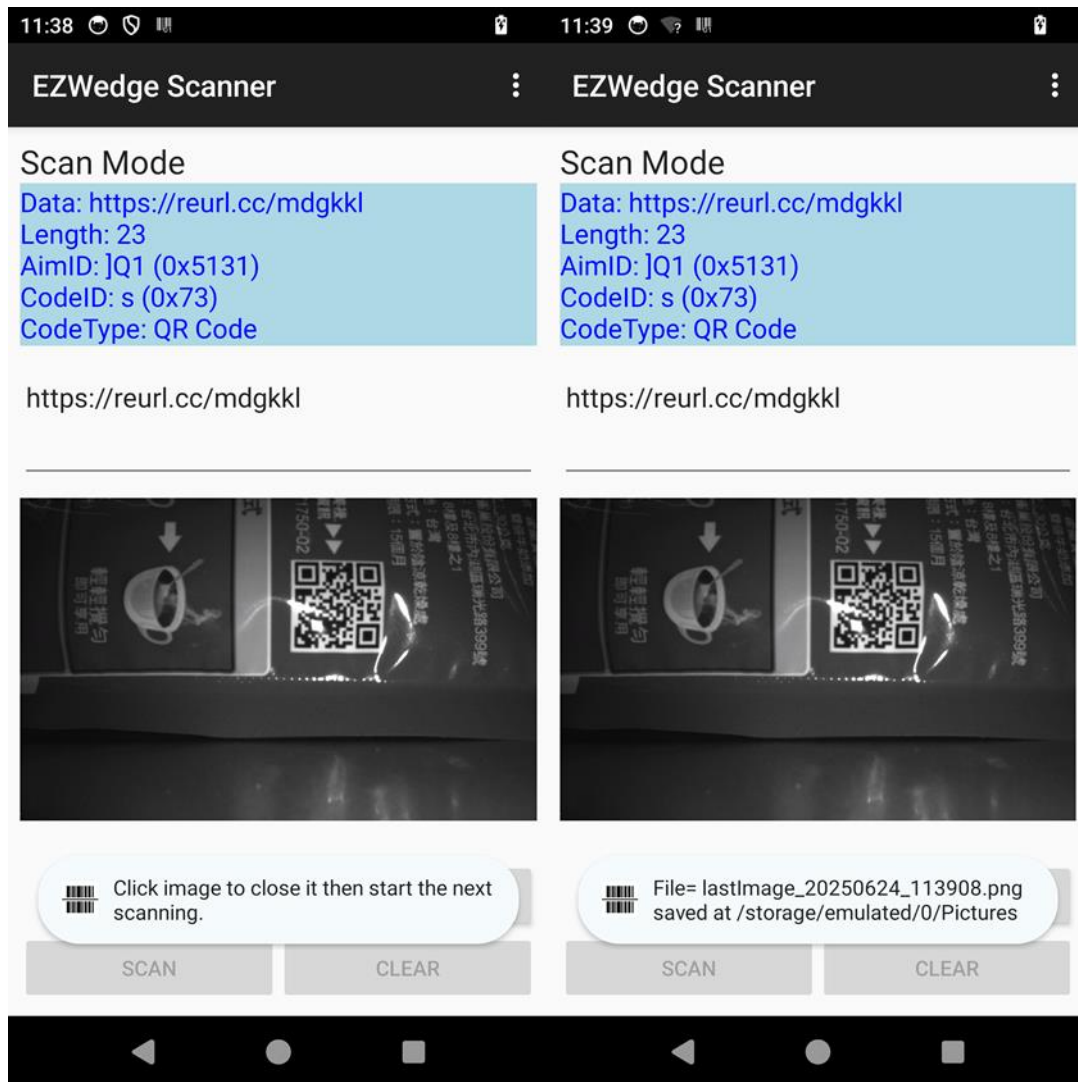

Notice: The Button "SCAN", "CLEAR" and right/left/pistol HW scan key were disabled while presenting the last image.

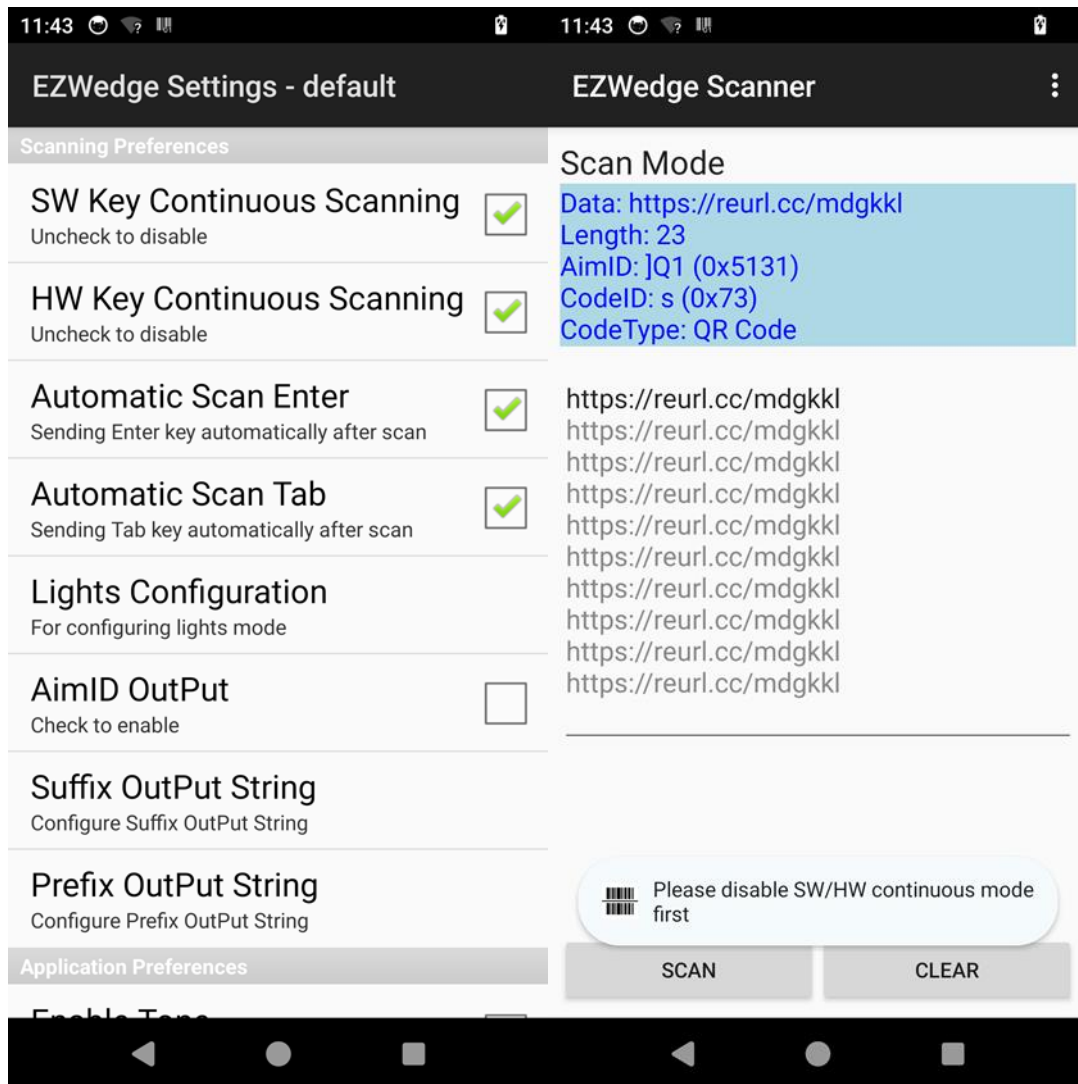

Notice: The “Get Last Image” can’t work on SW/HW Key Continuous Scanning enabled.

3.7.1.4 PROFILES FUNCTION

When clicking the Profiles option, there are two default profiles that present the current supported configuration:

EZWedge default Profile: For EZWedge Scanner App and as the base of all other Apps.

SmartTE Profile: For the preloaded SmartTE App.

For example, long press the “EZWedge default” item that allows editing Profile, Reset Profile, Enable All Symbology, Disable All Symbology and Set Symbology as default.

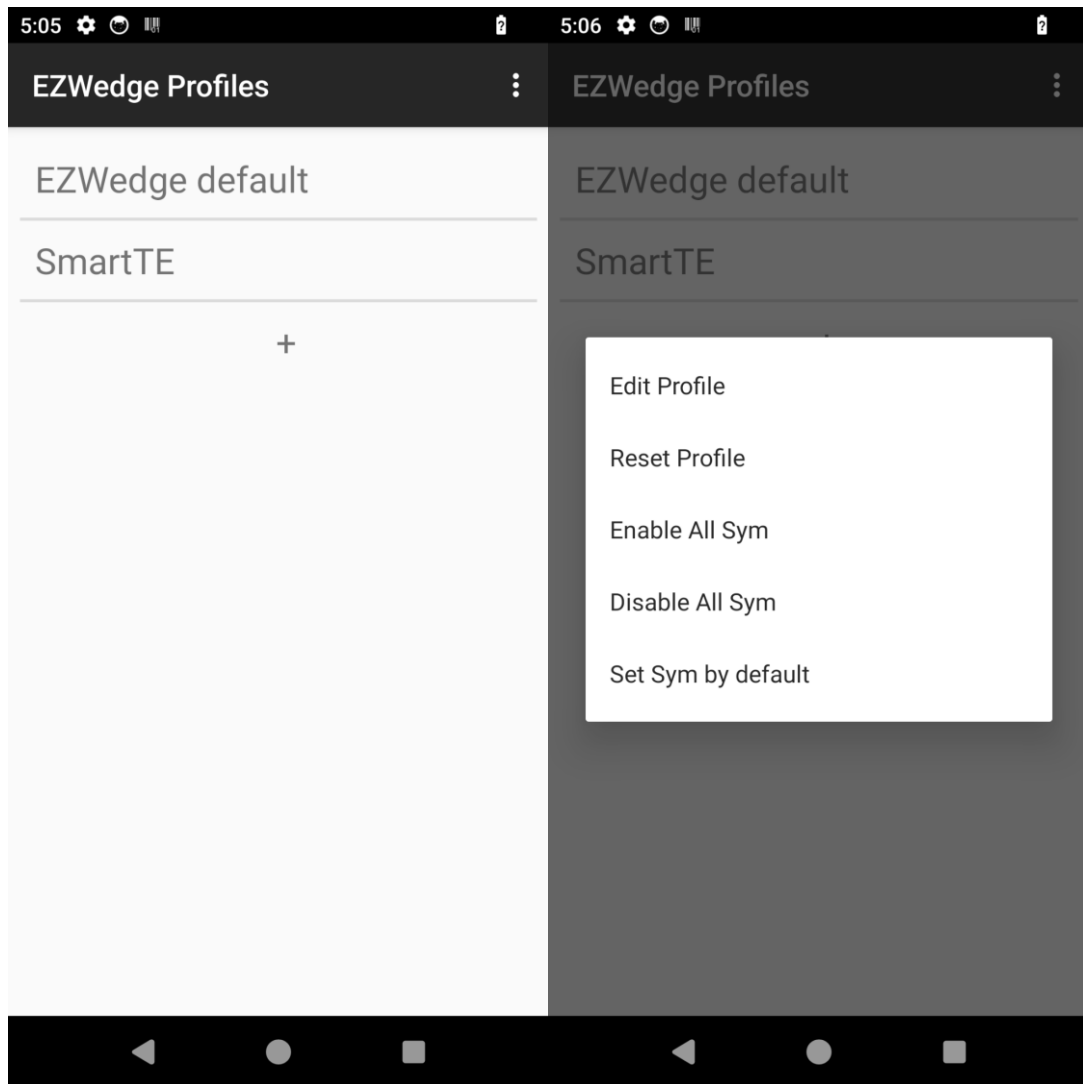

3.7.1.5 NEW PROFILE FUNCTION

Users can create a profile for their application, to click “+” to new a profile, this profile copies the EZWedge default profile content as the base and requires them to name it, like aa.

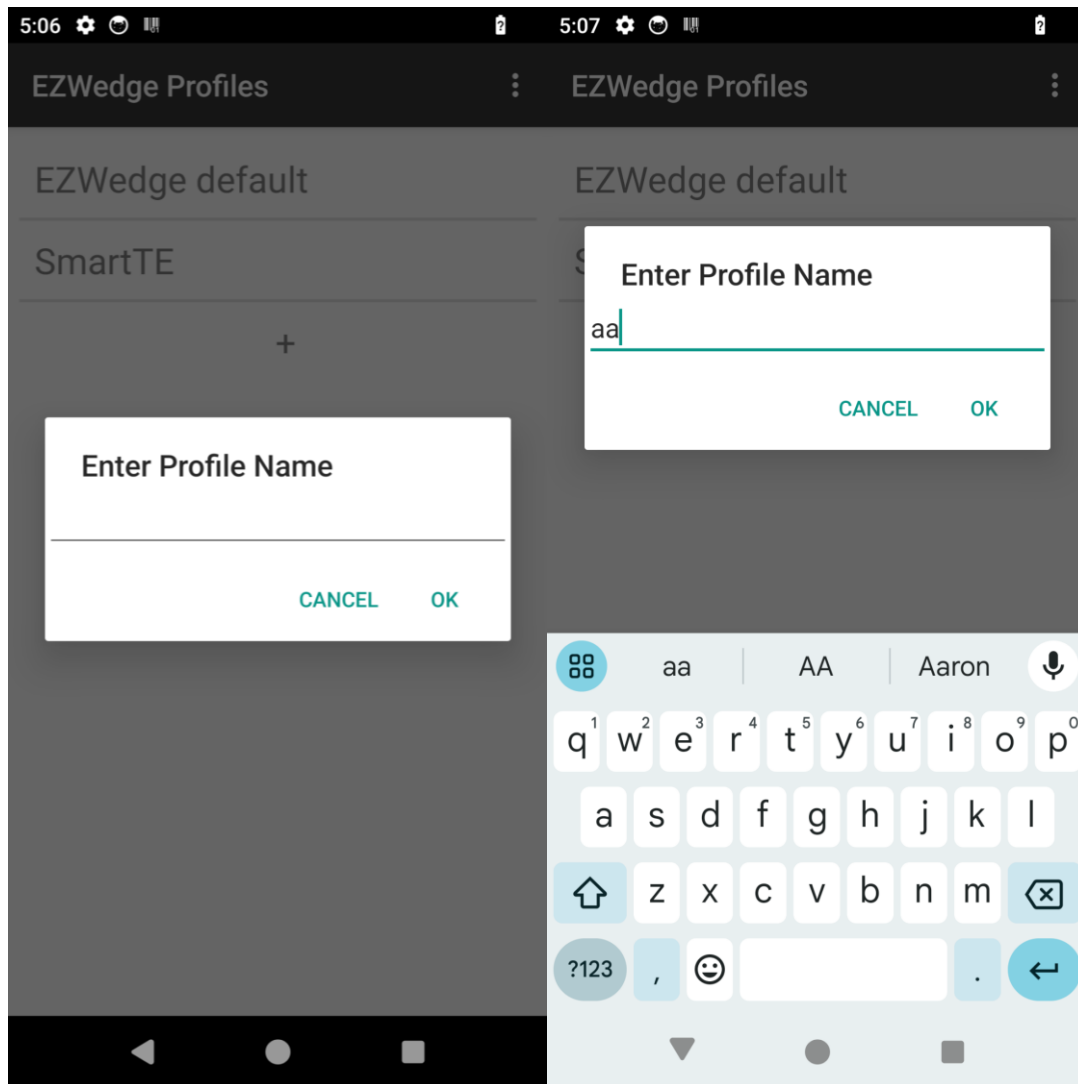

The new aa profile supports Edit Profile, Reset Profile, Delete Profile, Rename Profile and Enable All Symbology, Disable All Symbology and Set Symbology by default.

Click a profile, there is a new item “Associated Apps” which allows the user to choose the installed apps bound to the EZWedge Service.

When the selected app becomes the foreground app, triggering a scanning, EZWedge will apply an associated profile for this app automatically.

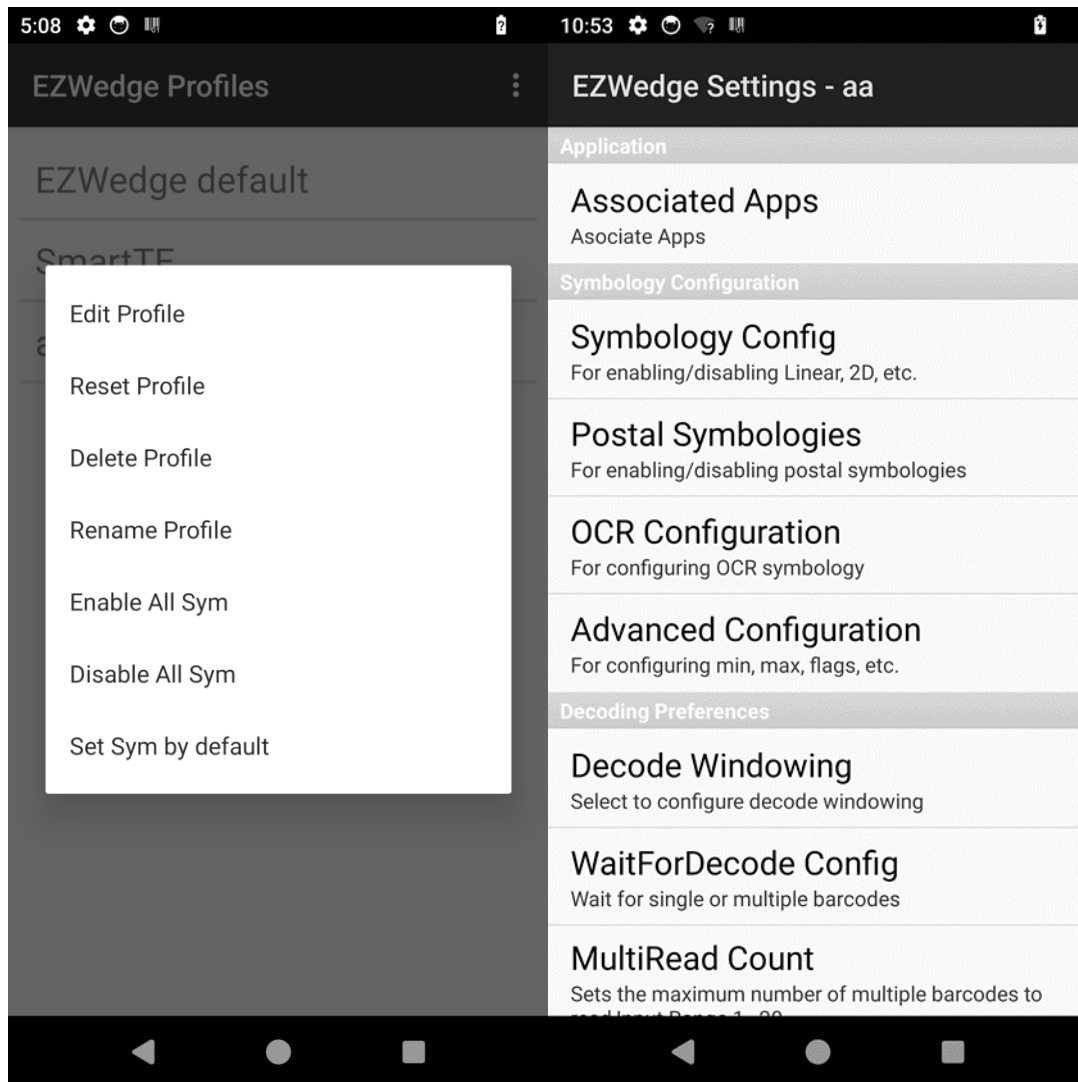

Click Associated Apps “+” to list all the system installed apps.

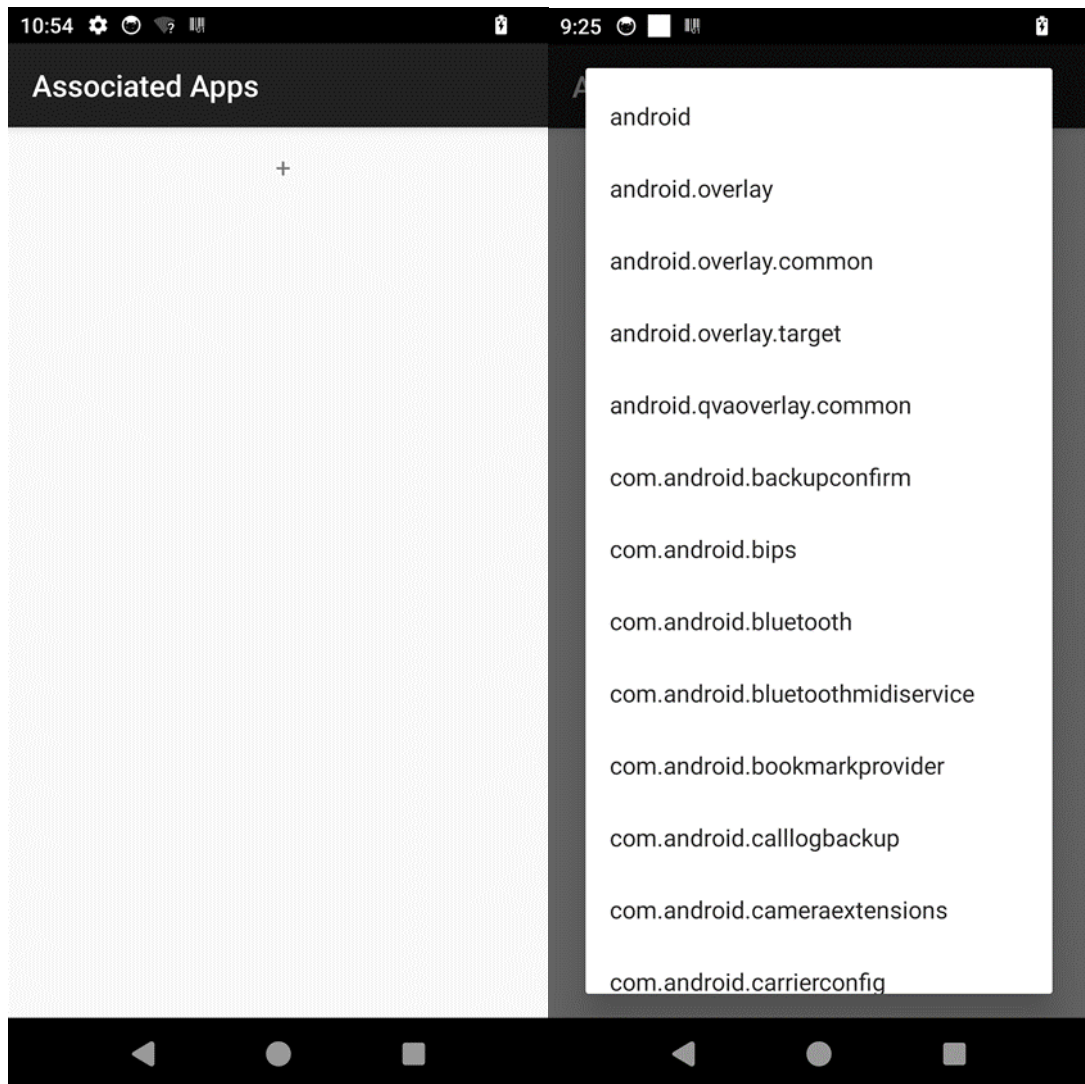

The profiles can be exported or imported to clone the same configuration settings.

For example, the newly created aa, bb profile.

Click "Export profile", list all exportable profiles, the all item means export EZWedge default, SmartTE,aa and bb into one db file.

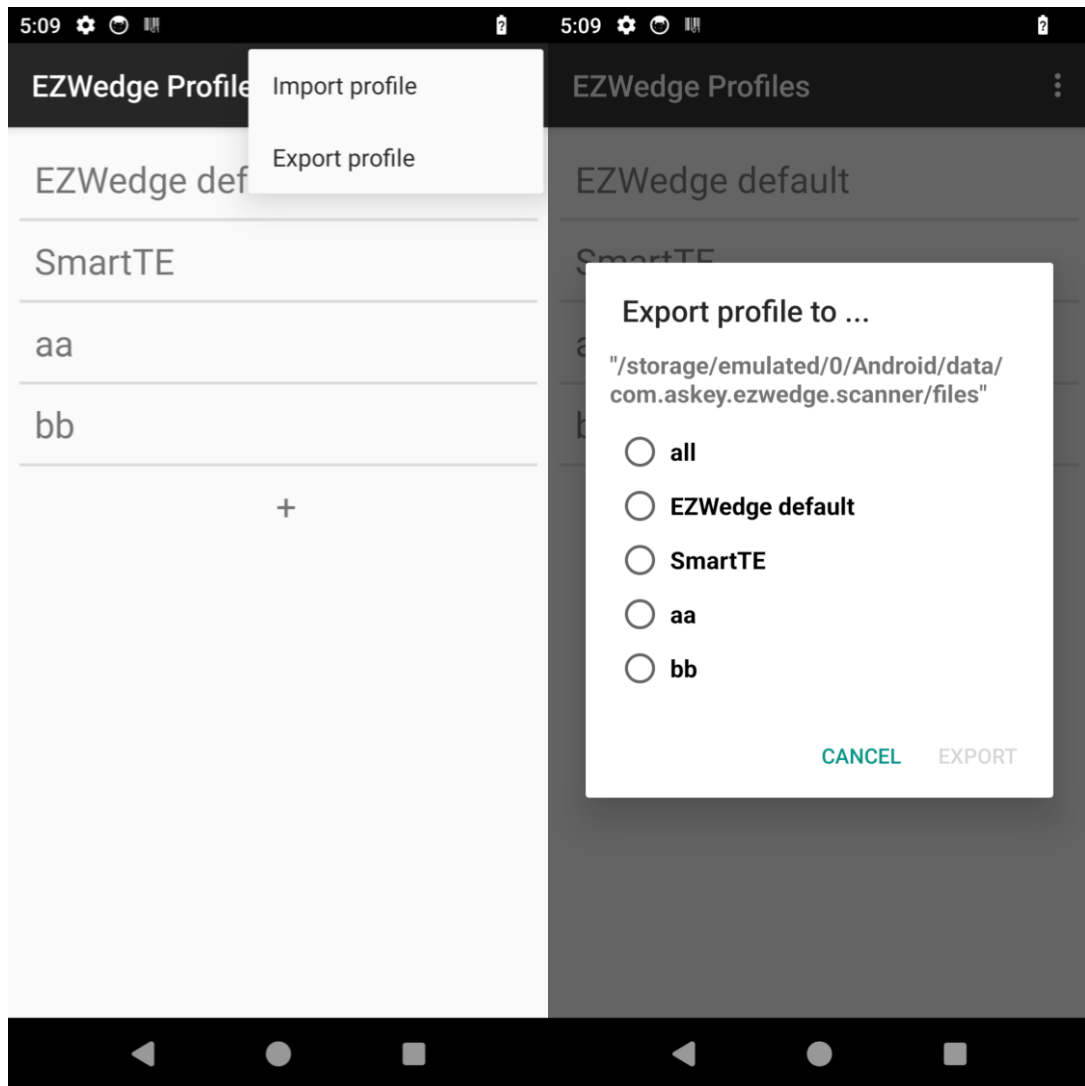

For example, to export aa profile, select aa profile, then tap on EXPORT.

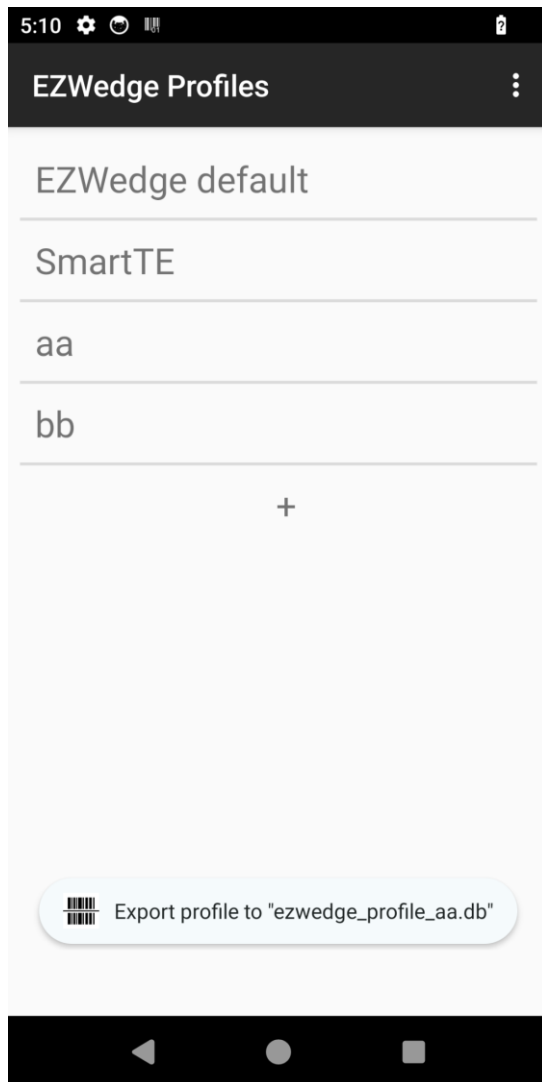

To remove aa, bb profile before importing the db files that were exported previously.

For example, long press aa profile, choose “Delete Profile” to delete it.

Then click “Import profile” that lists all importable db files from
“*storage/emulated/0/Android/data/com.askey.ezwedge.scanner/files*” path.

Note: The EZWedge default profile and SmartTE profile can’t be removed but updated.

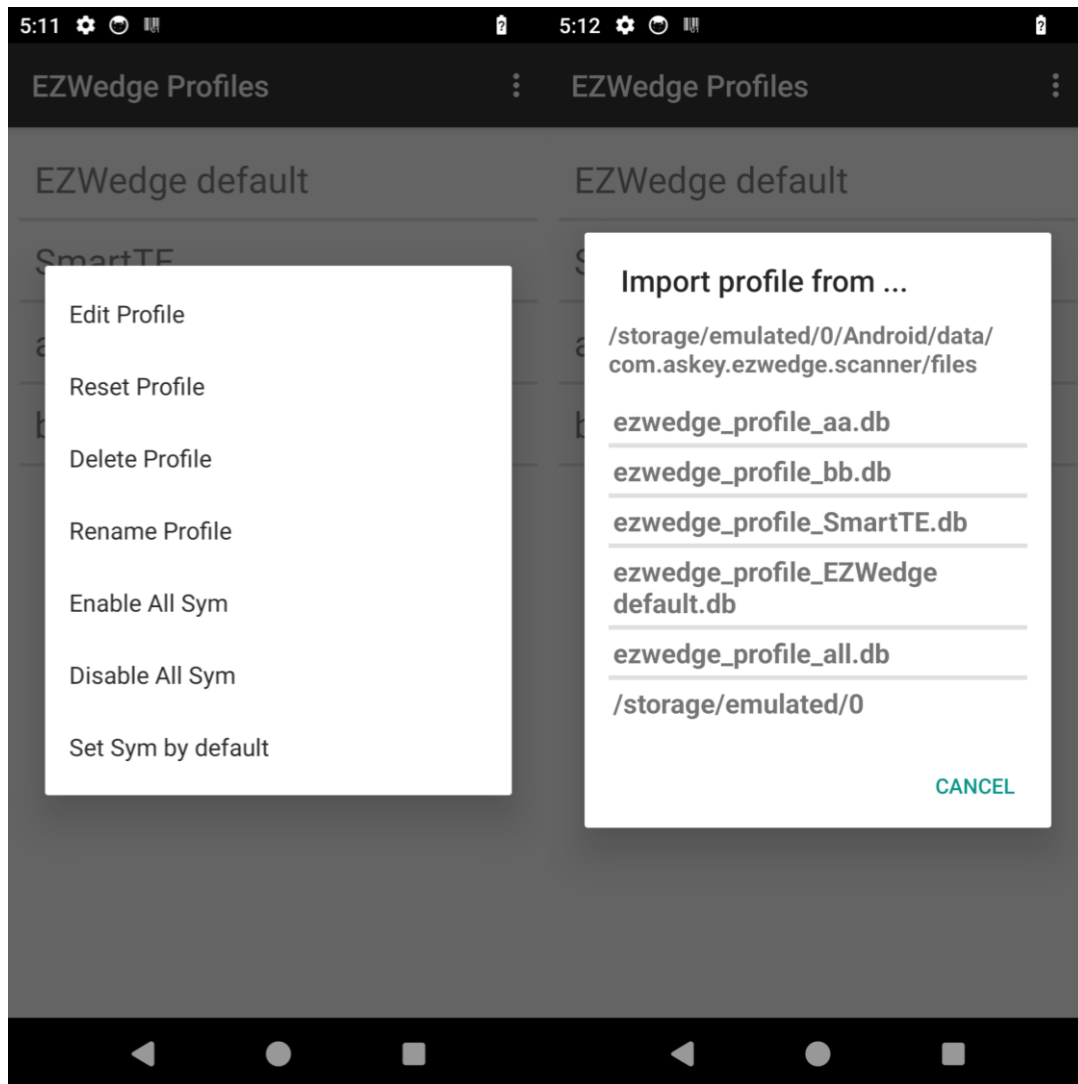

For example, to click “ezwedge_profile_all.db” to import it, the aa profile, bb profile were imported and EZWedge default profile and SmartTE profile were updated.

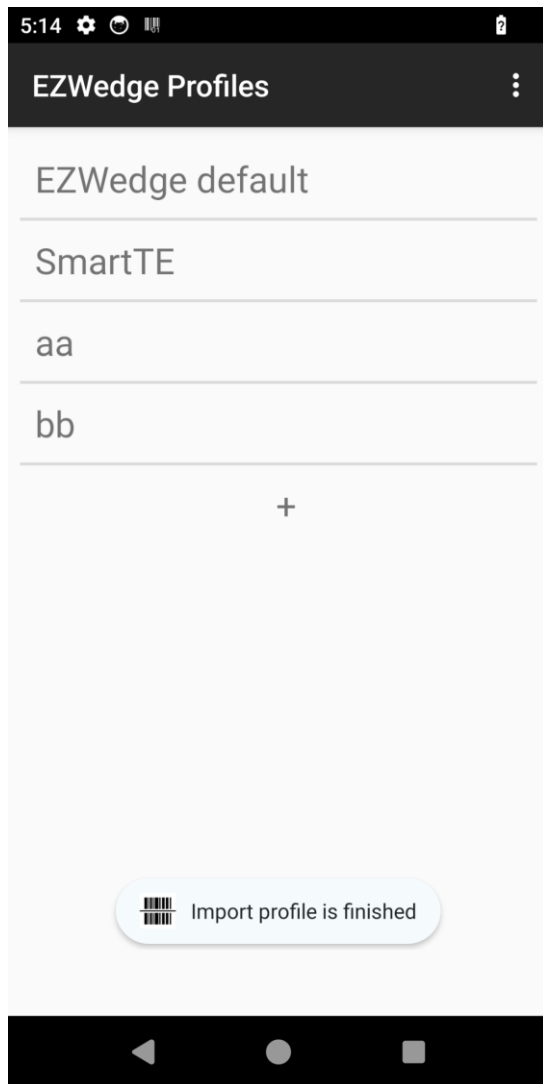

Or the exported db files that are at *"storage/emulated/0/Download"*, then click *"storage/emulated/0"*, *"Download"* to import the exported db files.

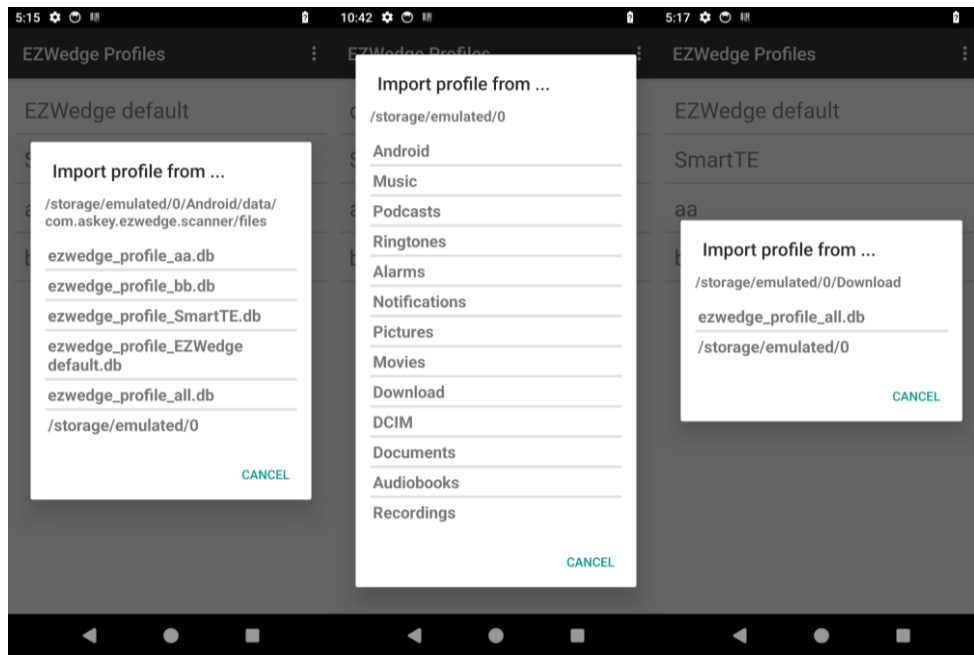

3.7.1.6 SETTINGS FUNCTION

The Settings page contains:

1. Symbology Configuration
2. Decoding Preferences
3. Scanning Preferences
4. Application Preferences

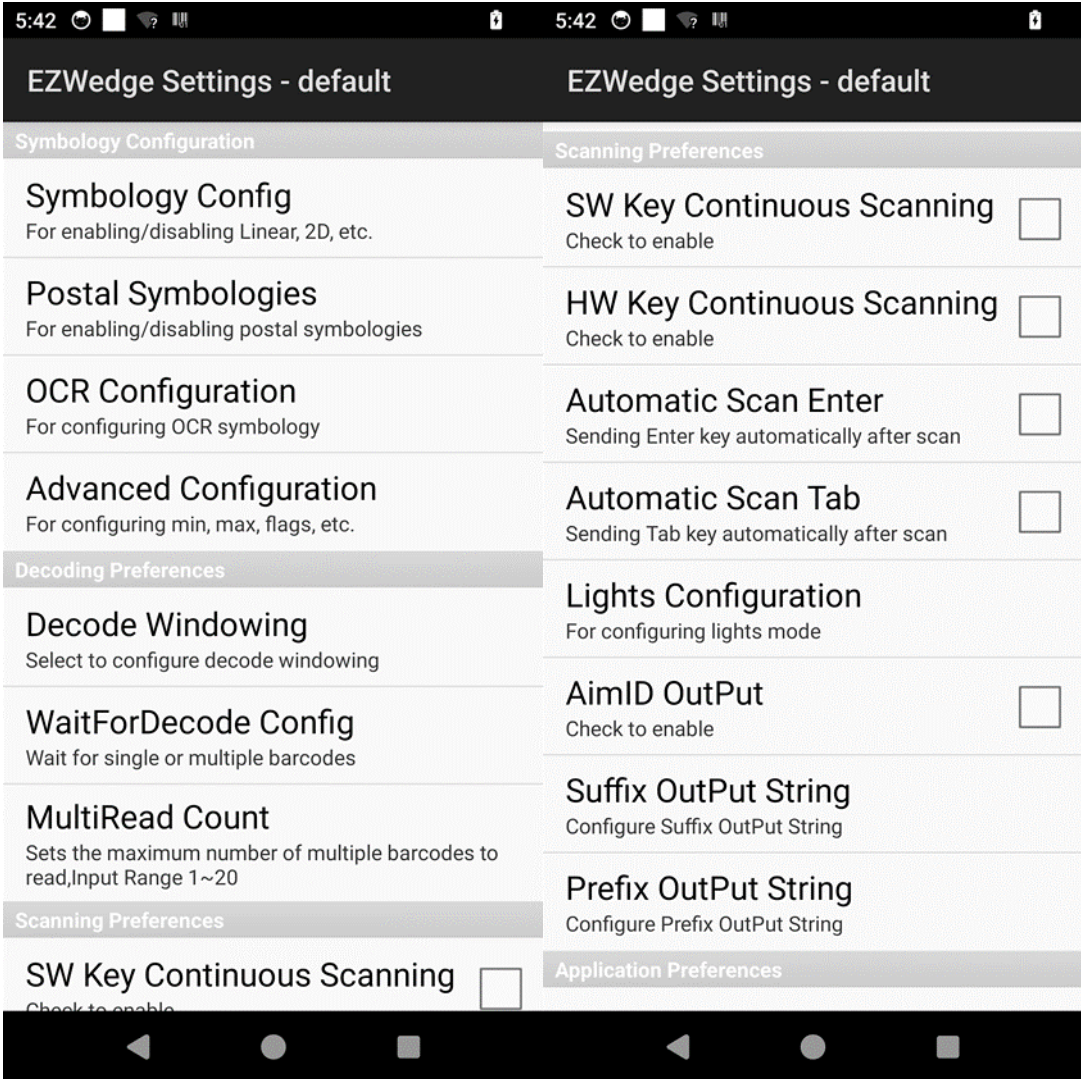

EZWedge Settings - default

Symbology Configuration

Symbology Config

For enabling/disabling Linear, 2D, etc.

Postal Symbologies

For enabling/disabling postal symbologies

OCR Configuration

For configuring OCR symbology

Advanced Configuration

For configuring min, max, flags, etc.

Decoding Preferences

Decode Windowing

Select to configure decode windowing

WaitForDecode Config

Wait for single or multiple barcodes

MultiRead Count

Sets the maximum number of multiple barcodes to read, Input Range 1~20

Scanning Preferences

SW Key Continuous Scanning

Check to enable

EZWedge Settings - default

Scanning Preferences

SW Key Continuous Scanning

Check to enable

HW Key Continuous Scanning

Check to enable

Automatic Scan Enter

Sending Enter key automatically after scan

Automatic Scan Tab

Sending Tab key automatically after scan

Lights Configuration

For configuring lights mode

AimID OutPut

Check to enable

Suffix OutPut String

Configure Suffix OutPut String

Prefix OutPut String

Configure Prefix OutPut String

Application Preferences

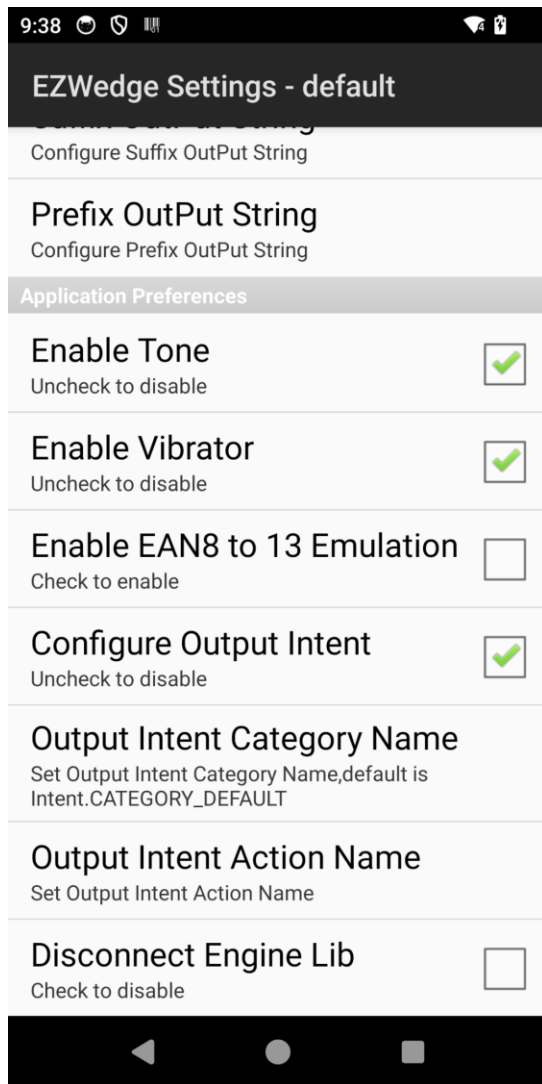

3.7.1.7 SETTINGS/SYMBOLGY FUNCTION

The Symbology settings contains Symbology Config, Postal Symbologies, OCR Configuration and Advanced Configuration.

This lists what Symbologies were supported by default.

For Advanced Configuration like EAN13, list its detail options can be chosen.

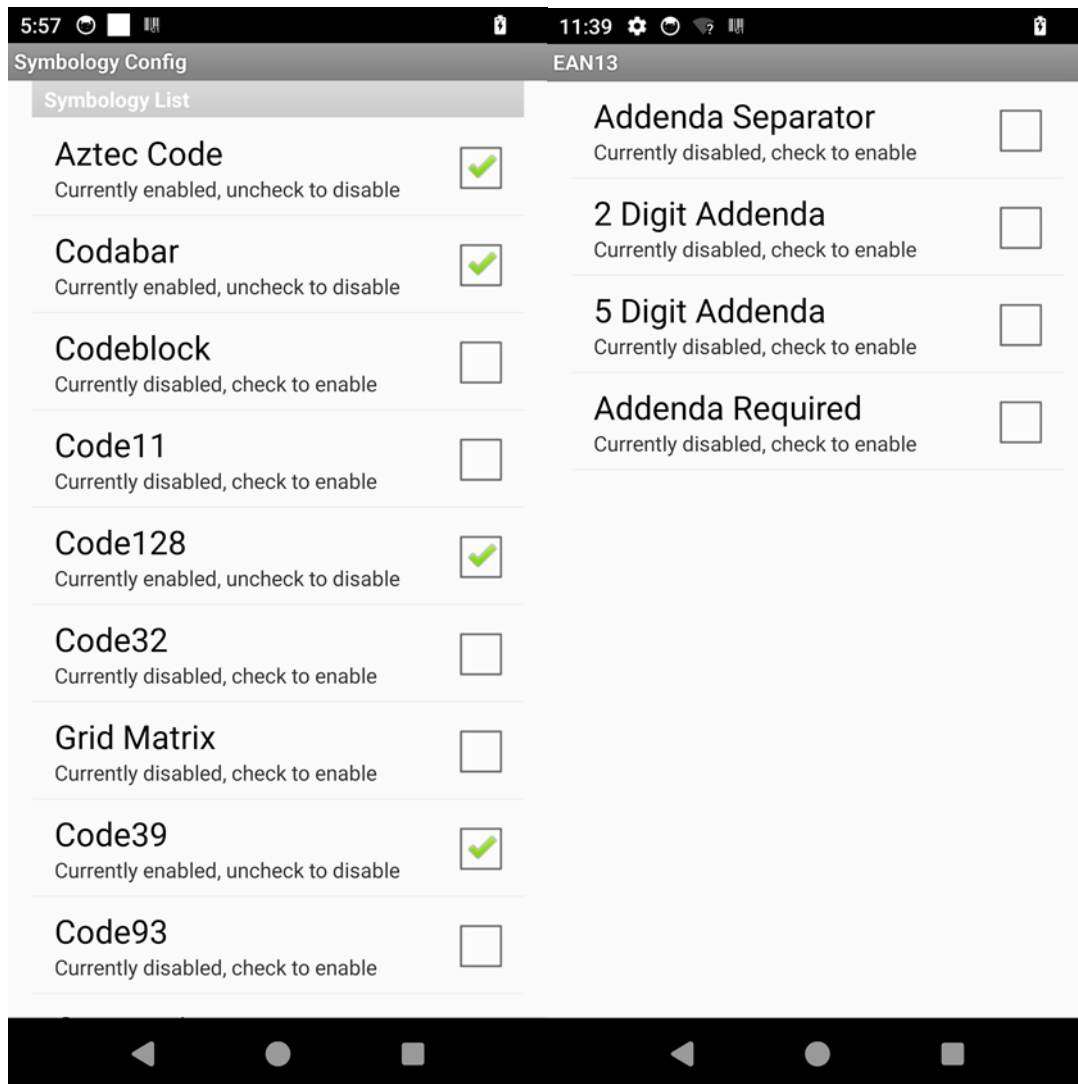

Postal Symbologies list what postal type was supported.

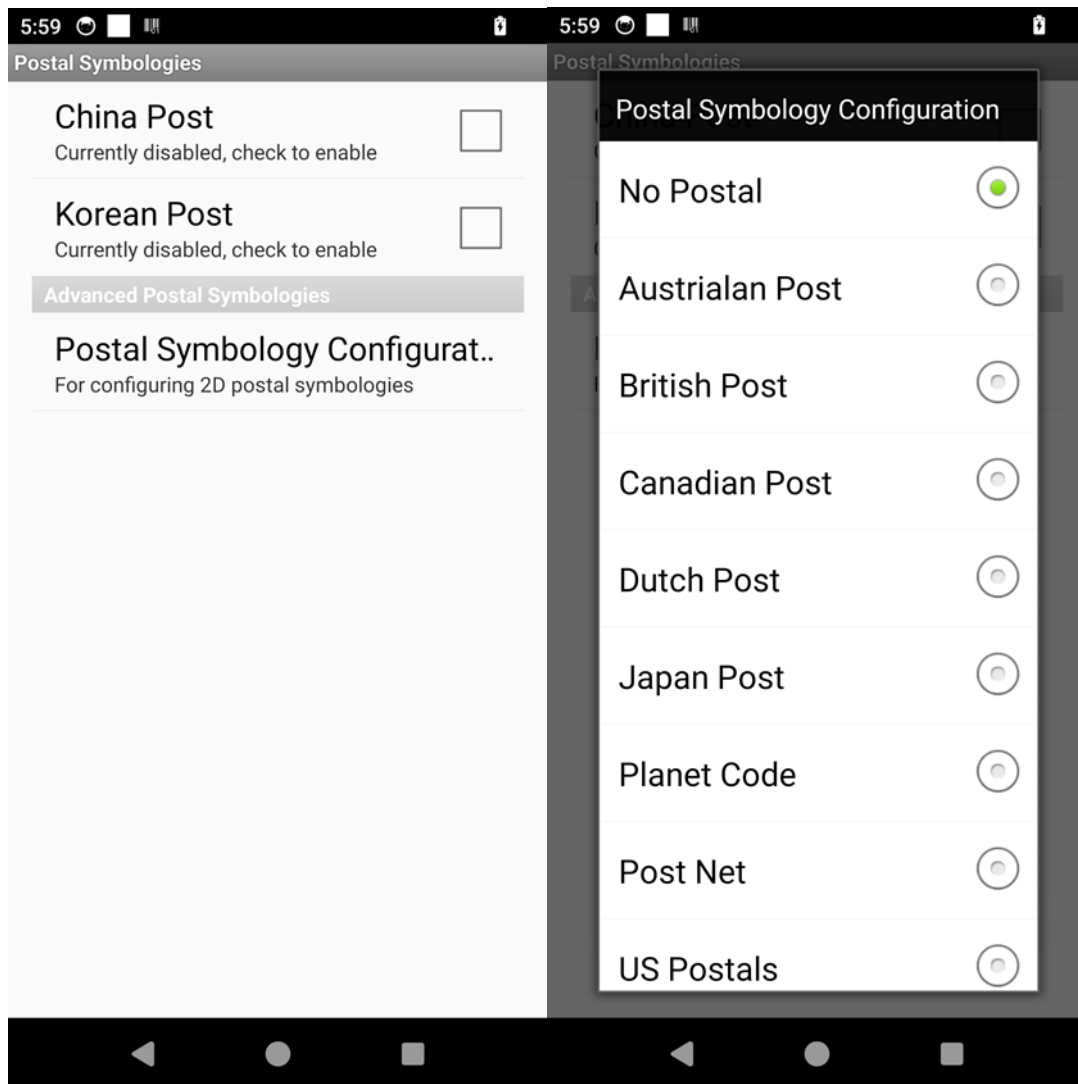

OCR(Optical Character Recognition) feature supports:

- User Defined template decode string
- Passport
- ISBN(International Standard Book Number)
- Price Field
- MicrE-13B(A font specifically designed for Magnetic Ink Character Recognition (MICR))

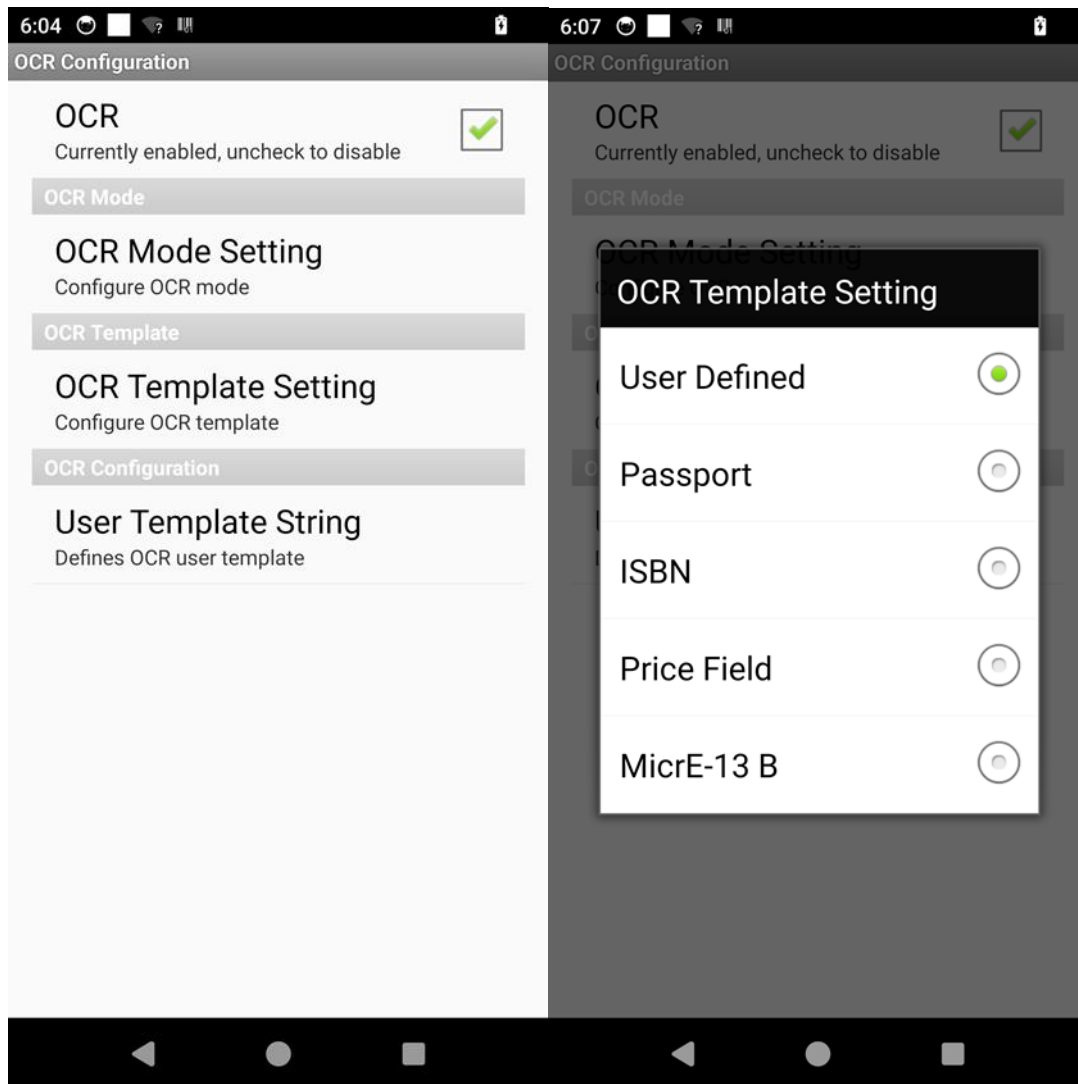

For “User Defined”, this allows the user to fill in the OCR string format they would like to decode.

Example: You need to read 8 numeric digits in either OCR-A or OCR-B:

12345678

6:24

OCR Configuration

OCR

Currently enabled, uncheck to disable

OCR Mode

User Template String

1,3,5,5,5,5,5,5,0

OK Cancel

User Template String

Defines OCR user template

q¹ w² e³ r⁴ t⁵ y⁶ u⁷ i⁸ o⁹ p⁰

a s d f g h j k l

↑ z x c v b n m ↵

?123 , ☺ . ✓

9:39

EZWedge Scanner

Scan Mode

Data: 12345678

Length: 8

AimID: Jo1 (0x6f31)

CodeID: 0 (0x4f)

CodeType: OCR

12345678

SCAN CLEAR

The string would be: 1 3 5 5 5 5 5 5 5 0

The breakdown:

Control Code	Description
1	New Template Code
3	Both OCR-A and OCR-B font
5	Wildcard: Numeric - 8 times
5	
5	
5	
5	
5	
5	
5	
0	End of Template

The more detailed control code definition in the chart.

Control Codes Chart

Control Code	Value	Argument
End of Template	0	
New Template	1	Font: 1 - OCR-A 2 - OCR-B 3 - Both A & B 4 - MICR 5 - Semi
New Line	2	
Define Group Start	3	ID [001-255]
Define Group End	4	
Wildcard: Numeric	5	[0-9]
Wildcard: Alpha	6	[A-Z uppercase]
Wildcard: Alphanumeric	7	[0-9] [A-Z uppercase]
Wildcard: Any (including space)	8	
Defined Group	A	ID [001-255]
In Line Group Start	B	
In Line Group End	C	
Checksum	D	Weights, Type, MOD
Fixed Character Repeat	E	[01-50]
Variable Character Repeat	F	Range Low [01-50] Range High [01-50]
ASCII Hex Value	x##	2 digits

3.7.1.8 SETTINGS/DECODING FUNCTION

The Decoding Preference settings support the Decode Windowing and MultiRead options.

The Decode Windowing supports the Off/Field Of View/Exact Aimer Mode Configuration and The Upper Left Window X/Y, Low Right Window X/Y allow input to a rectangle decode window for Field Of View Mode only.

The Off Mode decodes the barcode in its decodable range.

The Field Of View Mode decodes the barcode in the range of UpperLeftWindowX,Y and UpperRightWindowX,Y setting.

The Exact Aimer Mode decodes the barcode that is on the highest brightness Aimer spot.

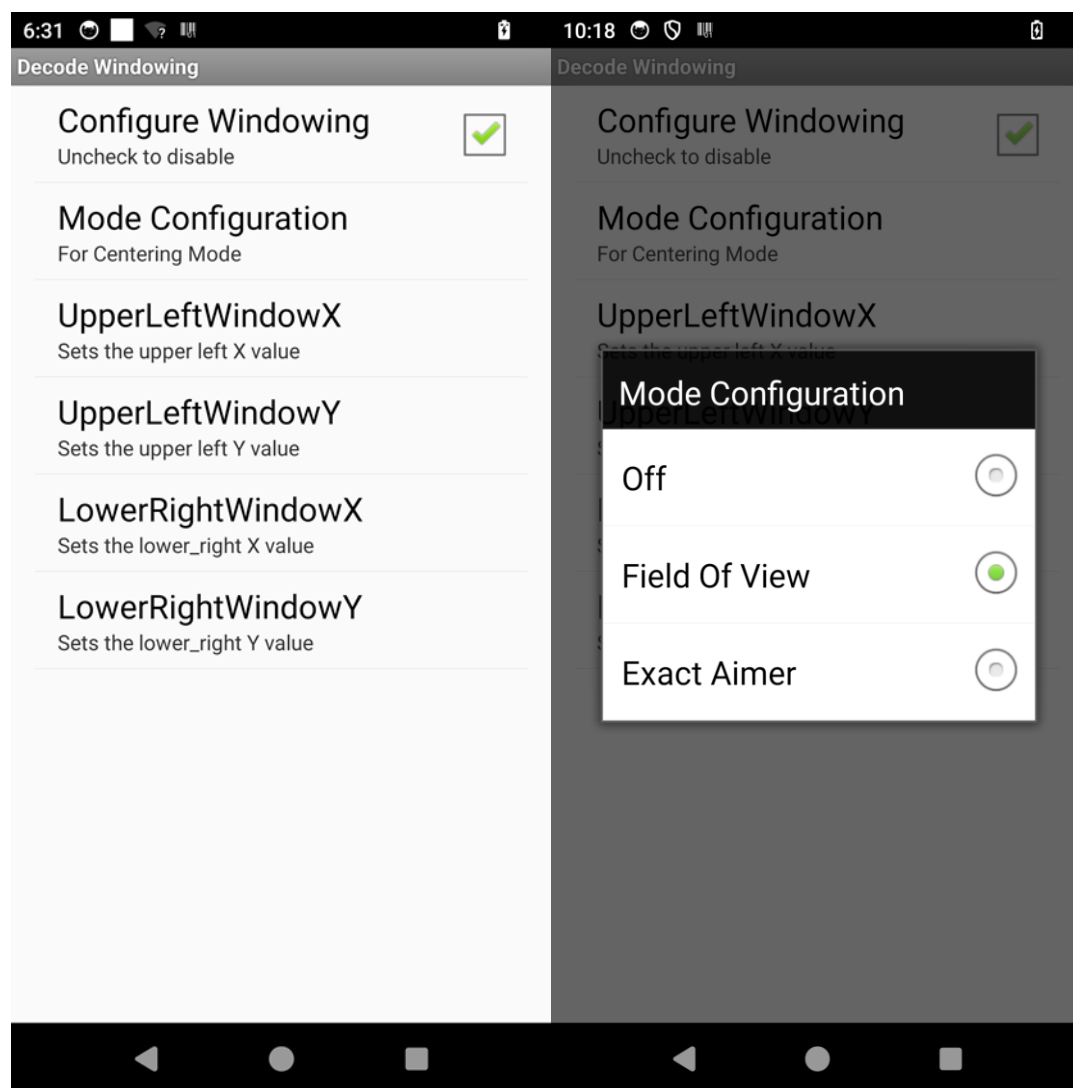

Field Of View Mode

UpperLeftWindowX,Y(0,0) /
LowerRightWindow X,Y(640,400)

UpperLeftWindowX,Y(640,0) /
LowerRightWindow X,Y(1279,400)

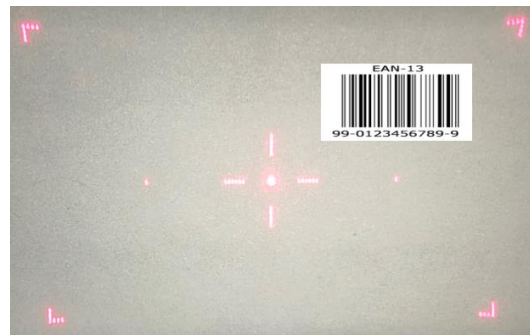
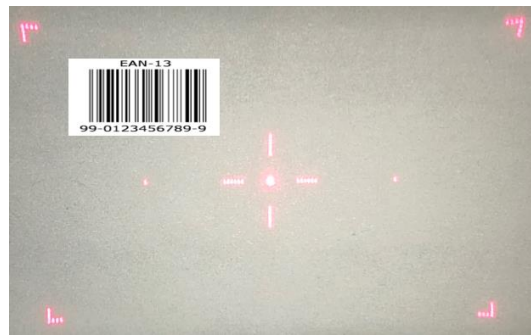

UpperLeftWindowX,Y(0,400) /
LowerRightWindow X,Y(640,799)

UpperLeftWindowX,Y(640,400) /
LowerRightWindow X,Y(1279,799)

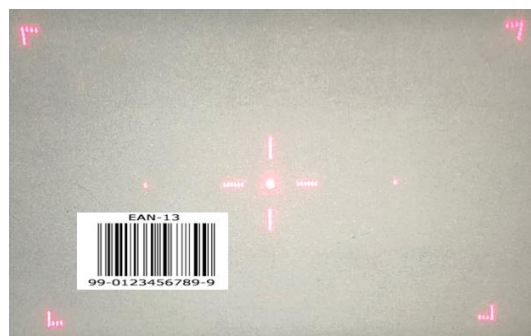

Exact Almer Mode



The MultiRead feature needs to set "Wait For Multiple" and set how many counts would like to get in one scan.

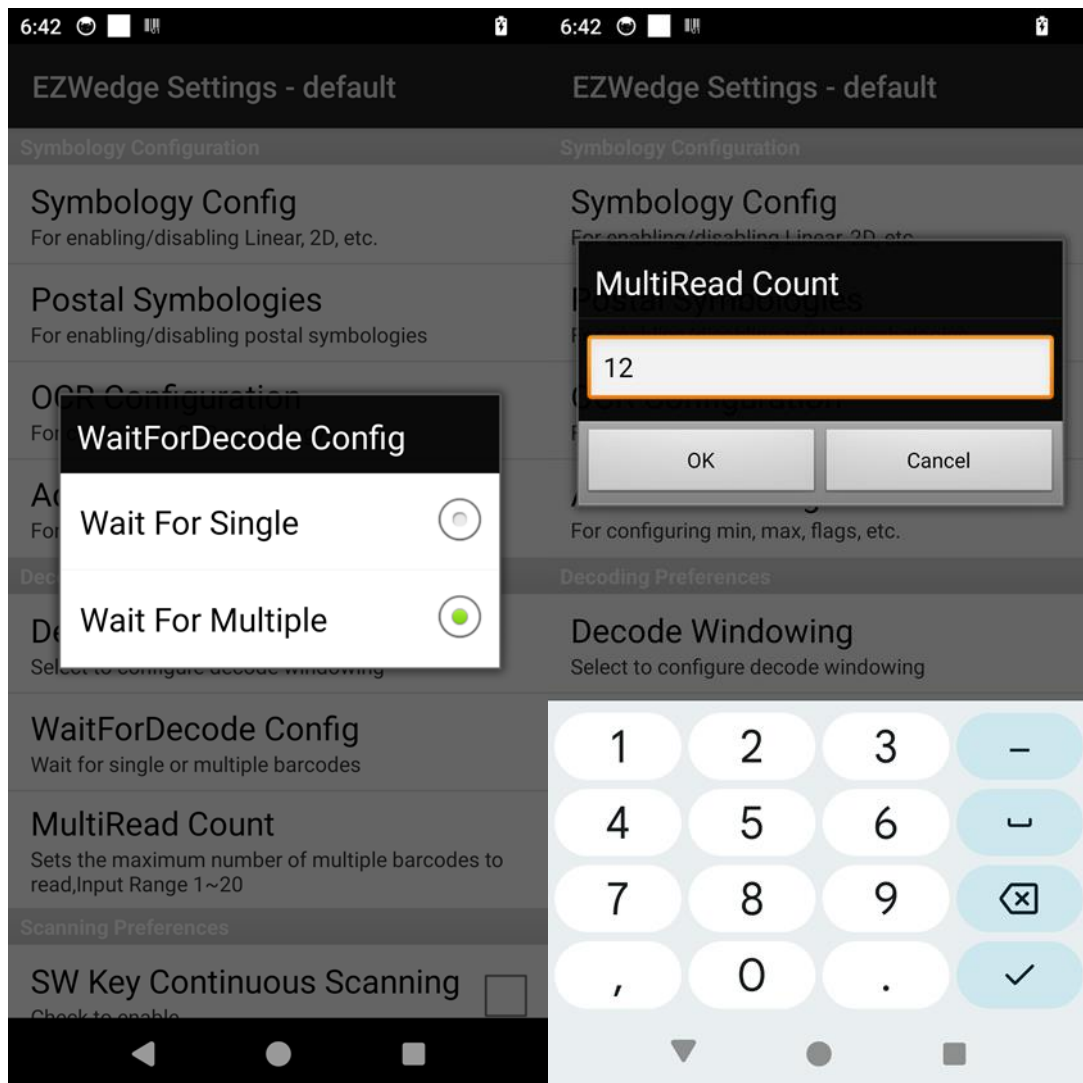

For this example, all 12 barcode data can be read in one scan trigger.

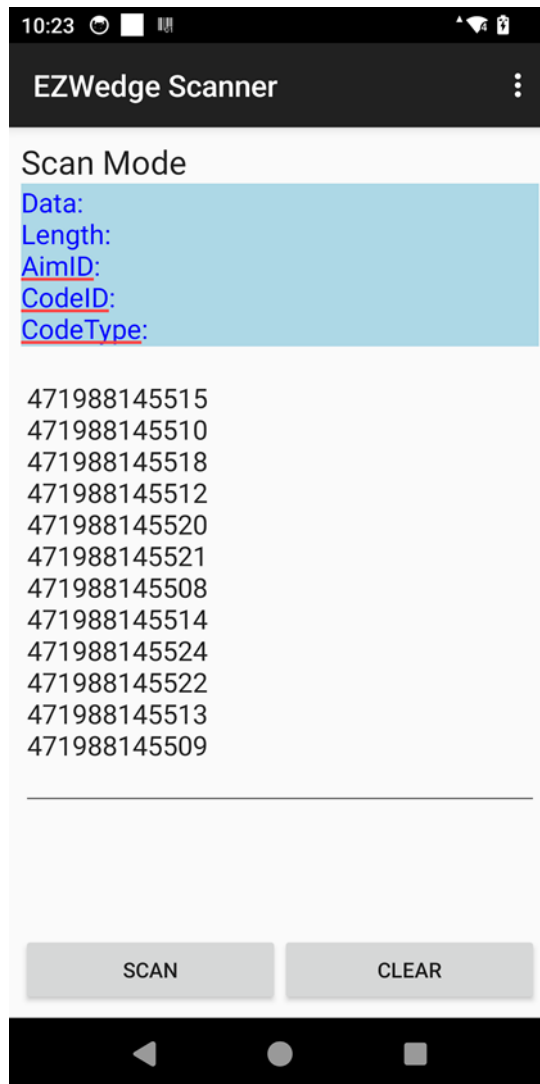

Notice: The OCR feature is disabled in MultiRead mode.

3.7.1.9 SETTINGS/SCANNING FUNCTION

The Scanning settings supports:

1. SW Key Continuous Scanning: Support SW key triggers a continuous scanning.
2. HW Key Continuous Scanning: Support HW key triggers a continuous scanning.
3. Automatic Scan Enter: Support to simulate the Enter key press/release at the end of scanned data.
4. Automatic Scan Tab: Support to simulate the Tab key press/release to switch to the next imputable field.
5. Lights Configuration: Support Aimer and Illumination control.
6. AimID OutPut: Support to add AimID as prefix of scanned data be sent as keyboard wedge.
7. Suffix OutPut String: Support to add a specified string append at end of scanned data.
8. Prefix OutPut String: Support to add a specified string append at the

beginning of scanned data.

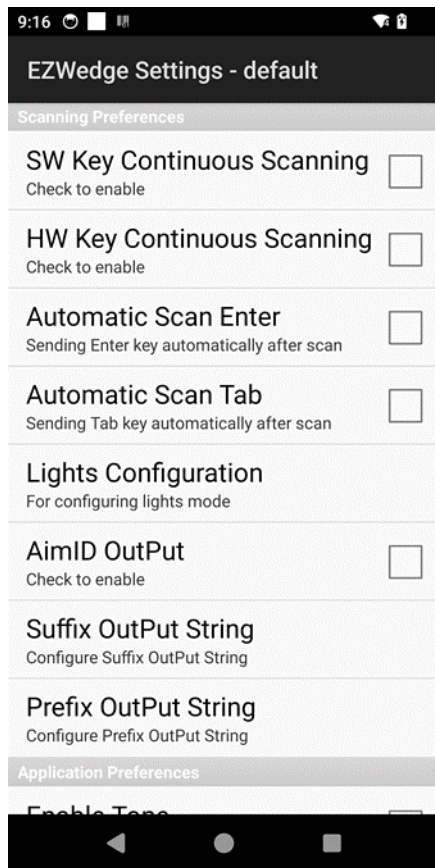

Notice: The Prefix OutPut String is higher priority than AimID OutPut when both were enabled.

3.7.1.10 SETTINGS/APPLICATION FUNCTION

The Application settings supports:

1. Enable Tone: Enable/Disable Tone.
2. Enable Vibrator: Enable/Disable Vibrator.
3. Emulation: Enable EAN8 to EAN13 Emulation.
4. Configure Output Intent: Send the intent to carry scanned data to application.
5. Output Intent Category Name: User can input the intent category name which the intent belongs to the category.
6. Output Intent Action Name: User can input the intent action name which is registered to listen to the intent action sent from Barcode service with scanned data.

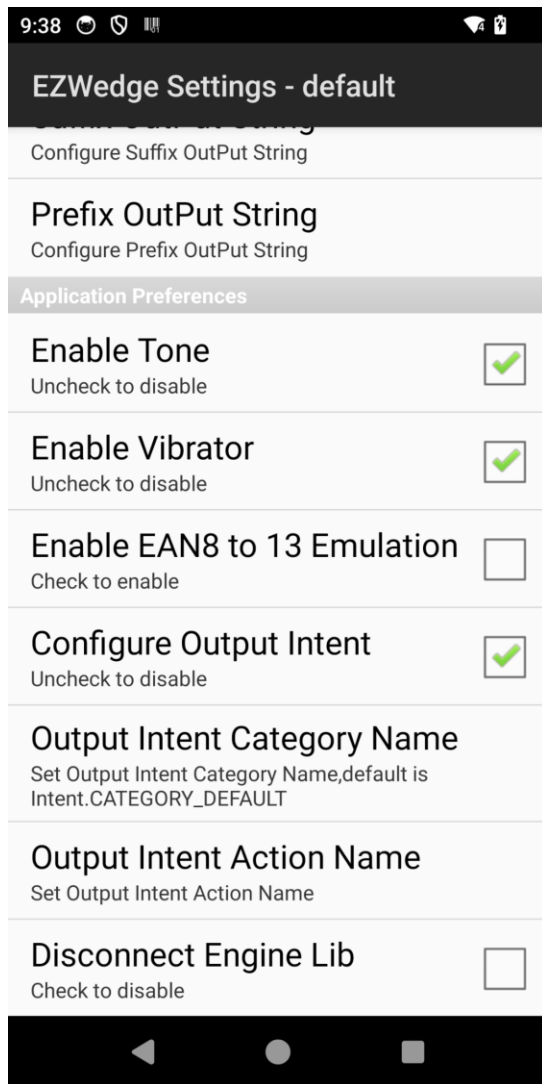

Notice: The beep tone volume was controlled by the volume key.

3.7.1.11 ABOUT FUNCTION

The About page shows the engine information.

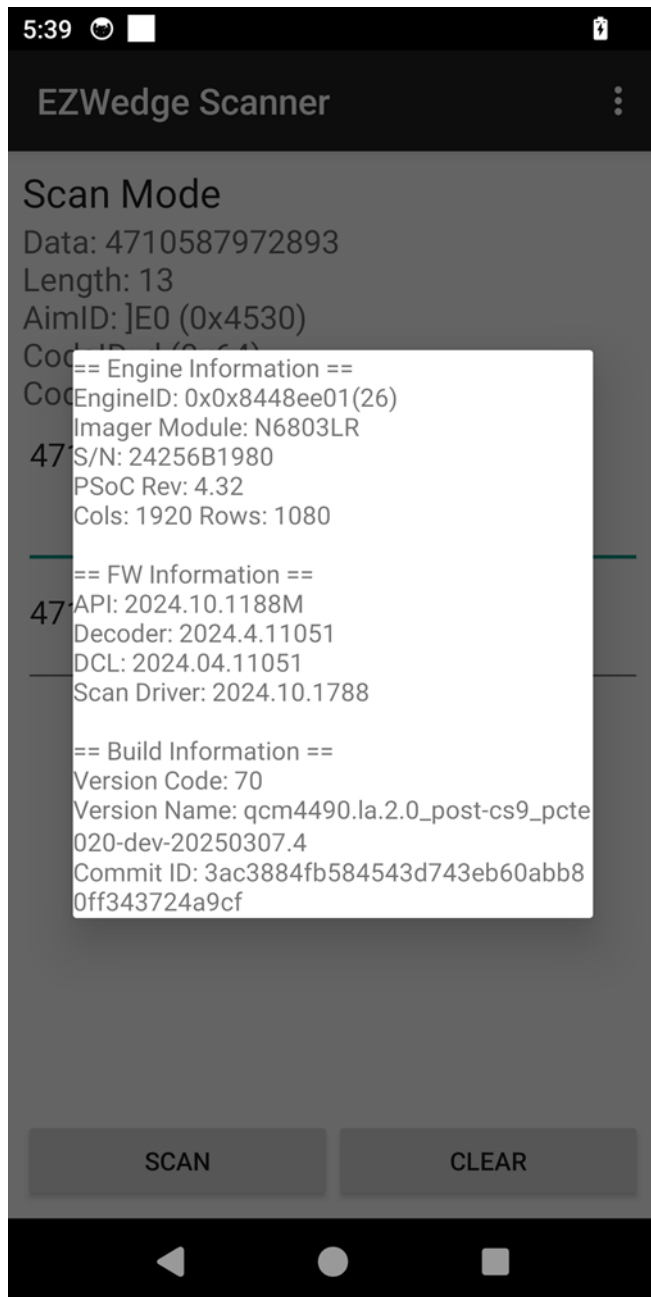

3.7.2 BARCODE SCANNING

Label Scan

1. Activate the EZWedge apk.
2. Press on the Blue Scan key on either side of the device to aim for a barcode label.
3. Hear a "beep" and see the scanned content on the screen once scan successfully.

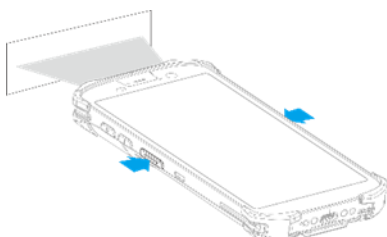

3.8 CAMERA

RC40 uses two cameras, one 16 mega pixel auto focus camera at rear side and one 8 mega pixel auto focus at front side

3.8.1 CAMERA FUNCTION

3.8.1.1 ZOOM

Press two fingers on the screen, pinch or spread your fingers, and the zoom in/out controls will appear on the screen.

3.8.1.2 CAMERA SWITCH

Touch the icon to switch 

3.8.2 PHOTOS TAKING FUNCTION

3.8.2.1 CAMERA SETTING

Step 1. On the home screen, tap the Camera app.

Step 2. Click the switch icon to switch between the front camera and the rear camera.

Step 3. Use the screen as a window, move and use your fingers to zoom in/out to the image you want to capture.

Step 4. The camera will automatically adjust the focus, and you can also click on the screen to correct the focus point

3.8.2.2 TAKE A PHOTO

Click the camera icon  or the volume down button to take a photo.

To view the photo after taking it, please click the preview icon at the bottom left of the screen.

3.8.3 VIDEO RECORDING FUNCTION

3.8.3.1 RESOLUTION

Resolution is FHD 1080P

3.8.3.2 LIGHT

Click the flash icon  at the top of the screen to flash on/flash off

3.8.3.3 RECORDING SETTING

Step 1. On the home screen, tap the Camera app. 



Step 2. Click Video on the lower left corner of the screen to switch to recording mode.

Step 3. Click the switch icon  to switch between the front camera and the rear camera.

Step 4. Use the screen as a window, move and use your fingers to zoom in/out to the screen you want to record.

Step 5. The camera will automatically adjust the focus, and you can also click on the screen to correct the focus point

3.8.3.4 RECORD VIDEO

Click the record icon  to start recording, then click the stop icon  to stop recording.

To view the recorded video file, please click the preview icon on the lower left of the screen

3.8.4 SETTINGS

1. General – These settings apply to both photo and video recording.
 - Store geographic location – Record geographic information when taking photos and recording videos.
 - Face Detection – Turn on (or off).
 - Storage – Default is Phone, but can select SD Card when inserted.
 - Picture Format – Only supports JPEG.
2. Camera - These settings apply only to taking photos.
 - Countdown Timer – Select Off (default), 2 seconds, 5 seconds, or 10 seconds.
 - Burst – Turn on (or off).
 - Grid Line - Turn on (or off).

- Image Size – Set the desired image size to 16M pixels (default for rear camera), 8M pixels (default for front camera), 5M, 3M, HD1080, 2M, HD720, 1M, WVGA, VGA, or QVGA.
 - Picture quality – Select Low, Standard, or High (default).
 - Exposure – Choose between -2, -1.5, -1, -0.5, 0 (default), +0.5, +1, +1.5, or +2.
 - White Balance – Choose from Auto (default), Incandescent, Fluorescent, Daylight, or Cloudy.
 - Shutter Sound - Turn on (or off).
 - Selfie Mirror – Optionally enable saving photos as a mirror image (Front camera only).
 - Selfie Flash – Optionally enable flash selfie (Front camera only).
3. Video Camera - These settings apply to video recording only.
- Video Quality - Set the video quality you want to record to HD 1080p (default), or HD 720p
 - Video duration - no limit.
 - Exposure – Choose between -2, -1.5, -1, -0.5, 0 (default), +0.5, +1, +1.5, or +2.
 - Noise Reduction - Choose Off, Fast, or High Quality (default).
 - Video Encoder - You can choose H264(default), or H265.
 - Audio Encoder - Select AMRNB, AAC (default), or OFF.
 - Video Rotation – You can choose to set it to 0 (default), 90, 180, or 270.
 - Time-lapse – Choose between off (default), or 0.5 seconds to 24 hours.
 - Video Frame Rate – 30FPS.
4. System
- Restore defaults – Select to restore to factory settings.
 - Version Info – Displays the version of the camera app.

3.9 QUICK SETTINGS MANAGEMENT

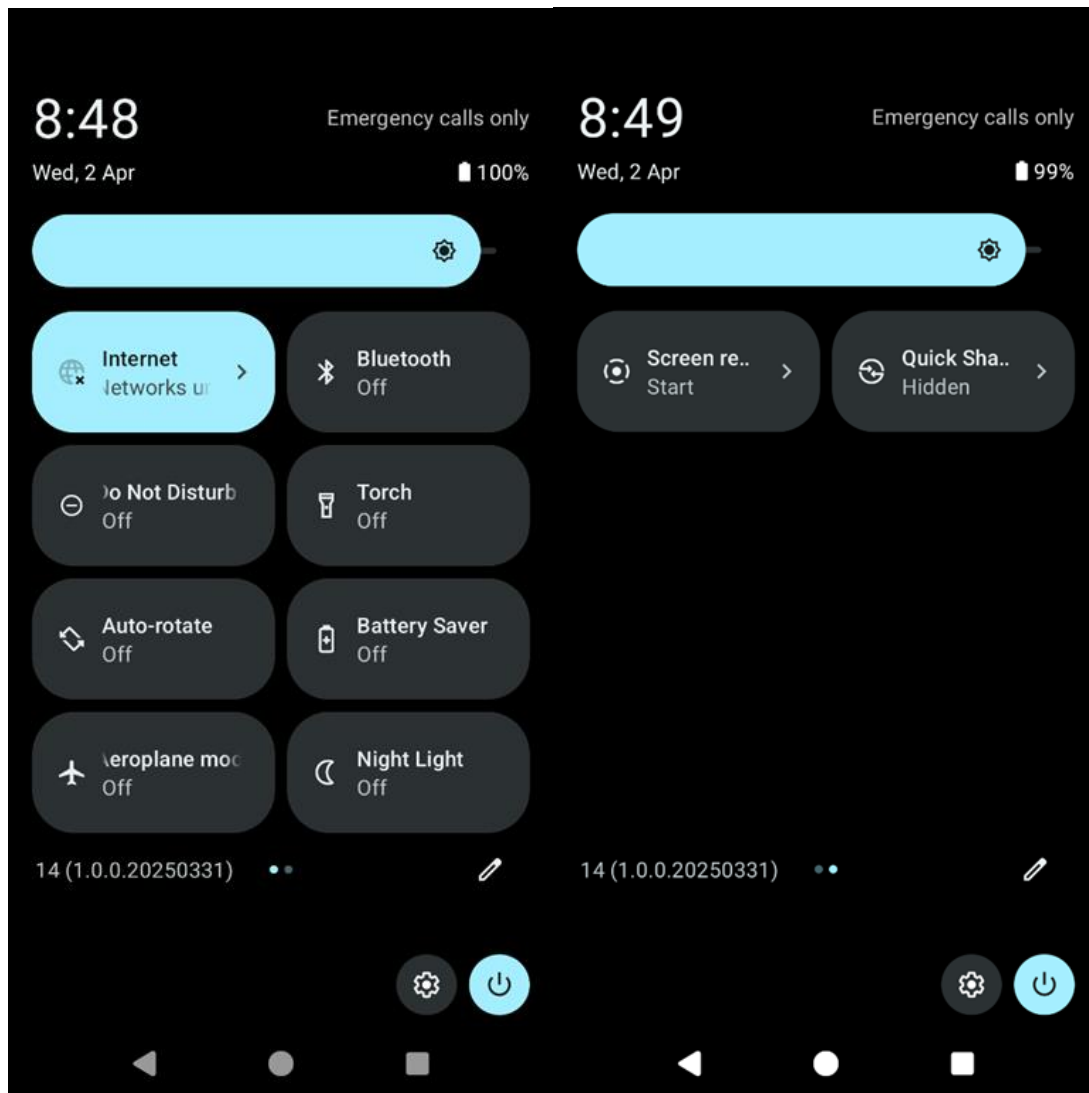

The Android Quick Settings panel provides quick access to commonly used settings and application features. Swipe down from the top of the screen to open this panel.

Brightness Adjustment

Located at the top, slide to adjust the screen brightness. The gear icon next to it will open the display settings.

Internet

Displays the current internet connection status. Tapping it expands Wi-Fi and mobile network options for easy switching or viewing available networks.

Bluetooth

Displays the Bluetooth on/off status. Tapping it quickly toggles Bluetooth, and long-pressing usually opens Bluetooth settings to pair new devices or manage paired ones.

Do Not Disturb

Displays the Do Not Disturb mode on/off status. When turned on, it silences notifications and calls. Tapping it quickly toggles, and long-pressing will open detailed Do Not Disturb settings.

Torch

Displays the flashlight function's on/off status. Tapping it quickly turns the flashlight on or off.

Auto-rotate

Displays the screen auto-rotate function's on/off status. When turned on, the screen automatically rotates based on the device's orientation. Tapping it quickly toggles.

Battery Saver

Displays the Battery Saver mode's on/off status. When turned on, it restricts background activity and performance to extend battery life. Tapping it quickly toggles, and long-pressing will open battery settings.

Aeroplane mode

Displays the Aeroplane mode's on/off status. When turned on, it disables all wireless connections, including Wi-Fi, mobile network, and Bluetooth. Tapping it quickly toggles.

Night Light

Displays the Night Light mode's on/off status. When turned on, it adjusts the screen's color temperature to reduce blue light, providing a more comfortable viewing experience at night. Tapping it quickly toggles, and long-pressing will open the Night Light options in display settings.

Brightness Adjustment

Located at the top, slide to adjust the screen brightness. The gear icon next to it will open the display settings.

Screen Recording

Displays the status of the screen recording feature, currently "Start." Tapping it will start or stop screen recording, and long-pressing will open screen recording settings.

Quick Share

Displays the status of the Quick Share feature, currently "Hidden." Tapping it will show or hide Quick Share options, allowing easy file sharing with nearby devices. Long-pressing will open Quick Share settings.

4. SETTINGS

4.1 DISPLAY

4.1.1 BRIGHTNESS

4.1.1.1 BRIGHTNESS LEVEL

Users can adjust screen brightness in the following ways:

Quick settings panel:

Swipe down the notification bar and adjust the brightness slider to change the screen brightness.

Display settings:

Go to Settings > Display > Brightness level to adjust the brightness manually or enable Auto-brightness.

Automatic brightness adjustment:

Once enabled, the system will automatically adjust the screen brightness according to the ambient light to save battery consumption.

It is recommended to use the automatic brightness function to obtain the best visual experience and power efficiency.

4.1.1.2 ADAPTIVE BRIGHTNESS

Adaptive Brightness automatically adjusts the screen brightness based on user habits and ambient light.

How to enable: Go to Settings > Display > Adaptive Brightness and turn on this feature.

Learning mode: The system will gradually learn the optimal brightness setting based on the user's habit of manually adjusting brightness.

Using adaptive brightness can reduce the need for frequent adjustments and improve the user experience

4.1.2 LOCK DISPLAY

4.1.2.1 LOCK SCREEN

Locking the screen keeps your device secure and prevents unauthorized users from accessing it.

Locking method:

Press the Power button to instantly lock the screen.

You can set a password, pattern unlock, and PIN "Settings > Security & Privacy > Screen lock".

The notification reads:

To display notification content on the lock screen, you can adjust it in "Settings > Display > Lock screen".

4.1.2.2 SCREEN TIMEOUT

The Screen Timeout feature automatically turns off the screen after a period of inactivity to save power.

How to set: Go to "Settings > Display > Screen timeout" and select the time for the screen to automatically turn off (e.g. 15 seconds, 30 seconds, 1 minute, etc.).

Recommended settings:

Reducing the screen timeout can save battery life but may affect user convenience.

If you read or watch content for a long time, it is recommended to extend the timeout.

These settings can help users manage screen time more effectively and improve device battery life.

4.1.3 INTERACTION

4.1.3.1 AUTO-ROTATE SCREEN

Auto-rotate screen

Enable: When the device detects a change in orientation, the screen automatically rotates (for example, from portrait to landscape mode), making it suitable for watching videos, browsing the web, or using certain apps.

Disable: The screen will be fixed in default orientation and will not change when the device is rotated.

4.1.3.2 SCREEN SAVER

Enable: Use screen saver to display a clock, photo, or other visual effect when the device is idle.

Disable: The screen saver will not be activated when the screen is idle, and the current screen will be maintained or the screen will enter sleep mode.

When to start: When "While charging" is set, the device will activate the screen saver only during charging.

4.1.3.3 GLOVE MODE

Turn on the glove mode to improve touch sensitivity, suitable for use when wearing gloves

Step 1. Swipe up from the home screen and tap Settings > Display

Step 2. Click Glove Mode to turn it on or off

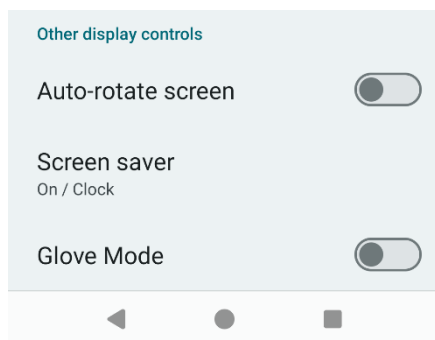

Support Glove types below

1. NITRILE synthetic rubber gloves
2. LATEX natural rubber gloves
3. WEX cotton gloves
4. MARUWA CHEMICAL anti slip gloves
5. Normal gloves

4.2 NOTIFICATION

4.2.1 MANAGE

4.2.1.1 APP NOTIFICATIONS

Tapping this allows configuring notification preferences for individual applications, such as whether to allow notifications, the notification style (sound, vibration, pop-up window), and the importance level of notifications. Customizable settings are available for different applications.

4.2.1.2 NOTIFICATION

When turned on, the device records recently received and snoozed notifications. This is very useful for viewing notifications that were accidentally swiped away earlier.

4.2.2 CONVERSATION

4.2.2.1 CONVERSATION

Displays conversations marked as priority. Currently shows "No priority conversations." Specific conversations in messaging applications can be set as priority to receive more prominent notifications.

4.2.2.2 BUBBLES

Configure whether to allow conversations to appear as floating icons (bubbles) on the screen, making it convenient to reply without leaving the current application. This feature is currently "On" and set to "Conversations can appear as floating icons."

4.2.3 SHOW NOTIFICATION

4.2.3.1 DEVICE & APP NOTIFICATIONS

Control which applications and devices can read notification content. This setting may be related to connected wearable devices or smart home devices.

4.2.3.2 NOTIFICATION ON LOCK SCREEN

Configure the notification content displayed on the lock screen. You can choose to show all content, hide sensitive content, or not show any notifications to protect personal privacy.

4.2.4 GENERAL

4.2.4.1 DO NOT DISTURB

Configure when to turn on Do Not Disturb mode, which exceptions are allowed (such as calls from specific contacts or scheduled alarms), and customize how notifications are silenced. This feature is currently "Off."

4.2.4.2 FLASH NOTIFICATIONS

Configure whether to use the device's camera flash or screen blinking to alert the user upon receiving a notification. This feature is currently "Off."

4.2.4.3 WIRELESS EMERGENCY ALERTS

Wireless Emergency Alerts (WEA) are emergency notifications sent by the government through mobile networks to warn the public of possible dangerous situations, such as natural disasters, missing children (America's Missing: Broadcasting Emergency Response, AMBER), national security threats, etc.

How to Manage Wireless Emergency Alerts

Open Settings → Safety & Emergency Assistance → Wireless Emergency Alert and select the feature you want to turn on or off.

4.2.4.4 HIDE SILENT NOTIFICATIONS IN STATUS BAR

When this option is turned on, notifications that are set to silent will not be displayed in the top status bar, helping to keep the status bar clean. This feature is currently turned off.

4.2.4.5 ALLOW NOTIFICATION SNOOZING

When this option is turned on, users can snooze certain notifications to be reminded later. This is useful for notifications that don't need immediate attention but should be addressed later. This feature is currently turned off.

4.2.4.6 NOTIFICATION DOT ON APP ICON

When this option is turned on, a small dot will appear in the upper right corner of an app icon when the app has unread notifications. This feature is currently turned on.

4.2.4.7 ENHANCED NOTIFICATIONS

When this option is turned on, the system may provide richer ways to interact with notifications, such as suggested actions and replies, based on the notification content. This feature is currently turned on.

4.3 SOUND & VIBRATION

4.3.1 AUDIO OUTPUT

Audio output covers a variety of ways, from built-in speakers, USB audio to Bluetooth devices, and can output audio through different paths, including:

- Built-in speaker (Speaker): Use the device's built-in speaker to play.
- USB Audio Out: Connect an external digital audio device (such as a USB Headset) via USB Type-C.
- Bluetooth: Connect to Bluetooth wireless headphones, speakers or car audio systems via Bluetooth. Once connected, the audio will be output to the stored device. Connection method: Settings -> Connected devices -> Pair new device

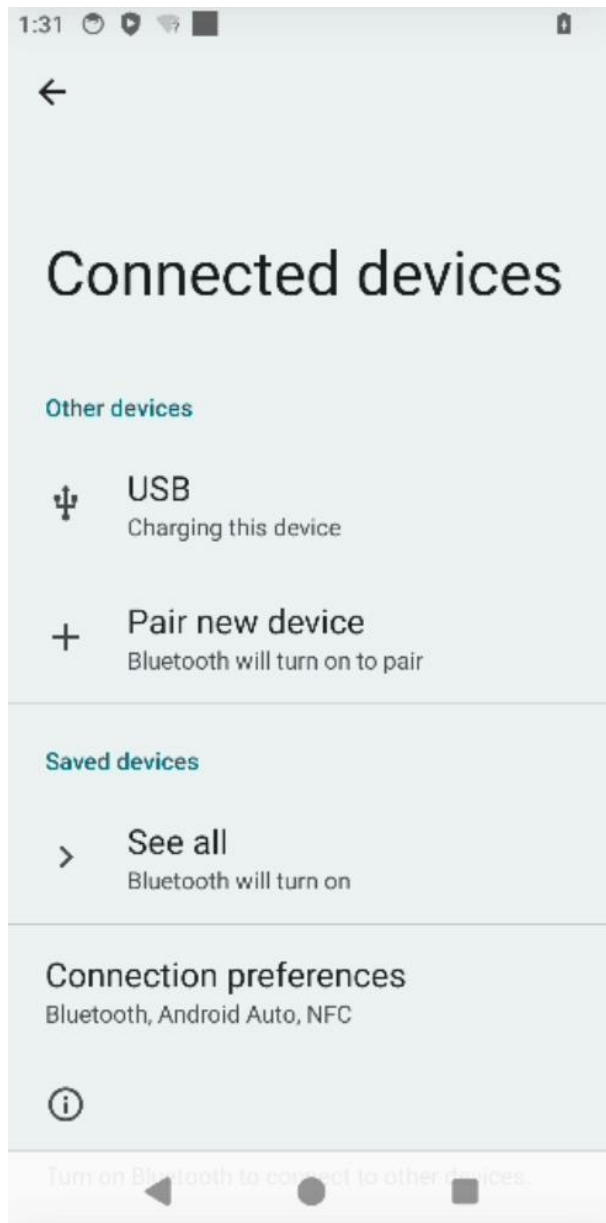

4.3.2 VOLUME

The volume is divided into different categories, and the volume of each category can be adjusted independently:

Media volume: Play music, movies, games, etc.

Call volume: Incoming call ringtone.

Ring volume: App notification sound.

Notification volume: Voice call volume.

Alarm volume: Alarm sound.

You can adjust the volume by adjusting the scroll bar. To adjust the volume:

Settings -> Sound and vibration

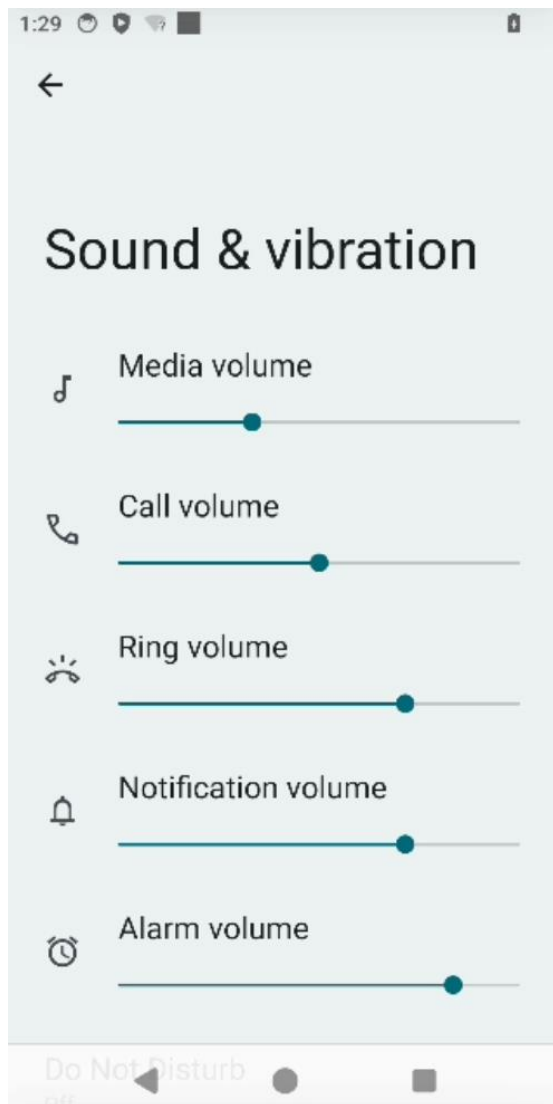

4.3.3 VIBRATION

Enable or disable vibration for device and touch.

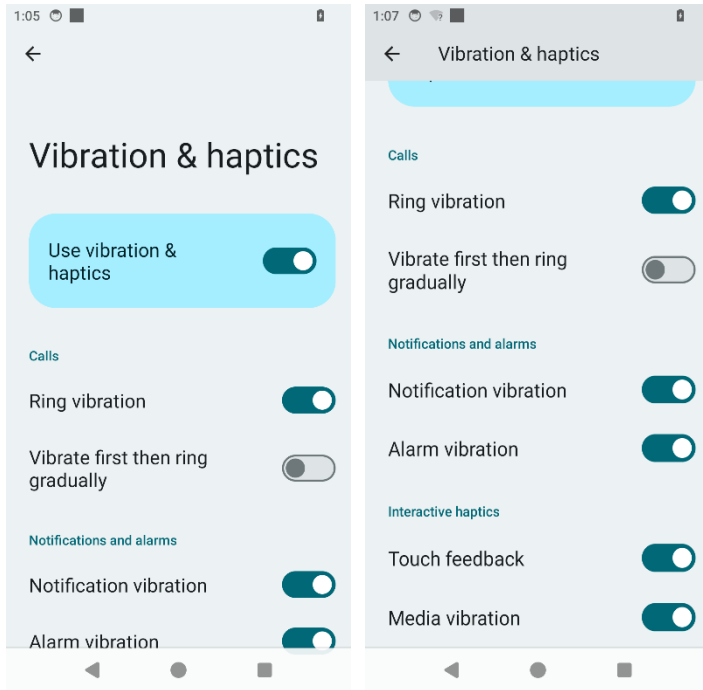

4.4 WALLPAPER

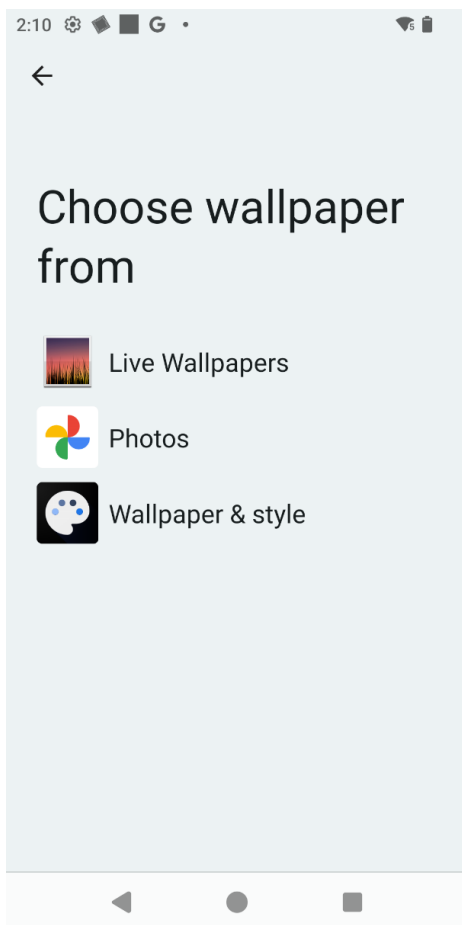

Choose a Wallpaper Source: Once on the Wallpaper settings page, the options will be displayed as shown in the screenshot:

Live Wallpapers: Select animated wallpapers that bring movement to the screen.

Photos: Choose favorite pictures from the device's gallery to use as a unique personal wallpaper.

Wallpaper & style:

Wallpaper & style: Browse and set from the device's built-in or provided selection of wallpapers. Options to Dark theme, Themed icons and App grid can be available here.

4.5 ACCESSIBILITY

4.5.1 SCREEN READER

TalkBack

This is a screen reader service that, when turned on, speaks to the items on the screen, such as buttons, images, and text. This feature is currently "Off." Tapping it allows you to turn it on and configure related settings.

4.5.2 DISPLAY

Select to Speak

When turned on, this allows users to select specific text on the screen and have the device read it aloud. This feature is currently "Off." Tapping it allows you to turn it on and use it.

Display size and text

Adjust the size of text and display elements on the screen to improve readability. Users can adjust font size, display size, and bold text options.

Color and motion

Adjust the screen's color settings, such as color correction, invert colors, and grayscale mode, to accommodate different visual needs. You can also control animation effects, such as removing animations to reduce visual distractions.

Extra dim

When turned on, the screen brightness is further reduced below the phone's minimum brightness, providing a more comfortable reading experience in low-light

environments. This feature is currently turned off; you can turn it on by sliding the switch.

Magnification

Provides screen magnification features to help visually impaired users see screen content more clearly. You can configure gestures or buttons to activate the magnification function. This feature is currently "Off." Tapping it allows you to configure it.

4.5.3 INTERACTION CONTROLS

Accessibility Menu

When turned on, a large on-screen menu appears, providing quick access to commonly used accessibility features and system controls, such as volume, brightness, screenshots, Google Assistant, etc. This feature is currently "Off." Tapping it allows turning it on and customizing the menu content.

Switch Access

Allows control of the device using one or more hardware switches or the front camera for actions like tapping the screen or scrolling. This is very useful for users with motor impairments. This feature is currently "Off." Tapping it allows configuration.

Timing controls

Adjust time-related settings for interactions, such as "Time to take action (Accessibility timeout)" and "Touch and hold delay," giving more time to interact with the device.

System controls

Provides additional system control options, which may include customizing the power button behavior, volume control, etc.

Vibration & haptics

Adjust the device's vibration intensity and haptic feedback settings, such as notification vibration and touch vibration. This feature is currently "On." Tapping it allows adjustment of detailed settings.

4.5.4 CAPTIONS

Live Caption

When turned on, the device automatically generates captions for media being played, including videos, podcasts, and voice messages.

Caption preferences

Adjust the display style of captions, such as text size, font, color, and background, to improve caption readability. This feature is currently "Off." Tapping it allows configuration.

4.5.5 AUDIO

Audio description

When turned on, supported movies and TV shows will play spoken descriptions of what's happening on the screen, helping visually impaired users understand the content. This feature is currently turned off; it can be turned on by sliding the switch.

Flash notifications

Configure whether the device's camera flash or screen blinks to alert about notifications. This feature is currently "Off."

Hearing devices

Manage connected hearing devices. If hearing aids or other compatible devices are paired with the phone, their settings can be adjusted here. Currently, "No hearing devices connected" is indicated.

Audio adjustment

Customize audio output for different hearing needs. Options to adjust sound balance between left and right ears or enable a mono audio setting might be available here.

4.5.6 GENERAL

Accessibility shortcuts

Configure shortcuts to quickly access accessibility features, such as using volume keys or gestures to turn on features like TalkBack or Magnification.

Text-to-speech output

Adjust settings for text-to-speech engines, including preferred engine, speech rate, and language. This affects how the device reads text aloud for features like TalkBack and Select to Speak.

4.6 SECURITY

4.6.1 SECURITY STATUS

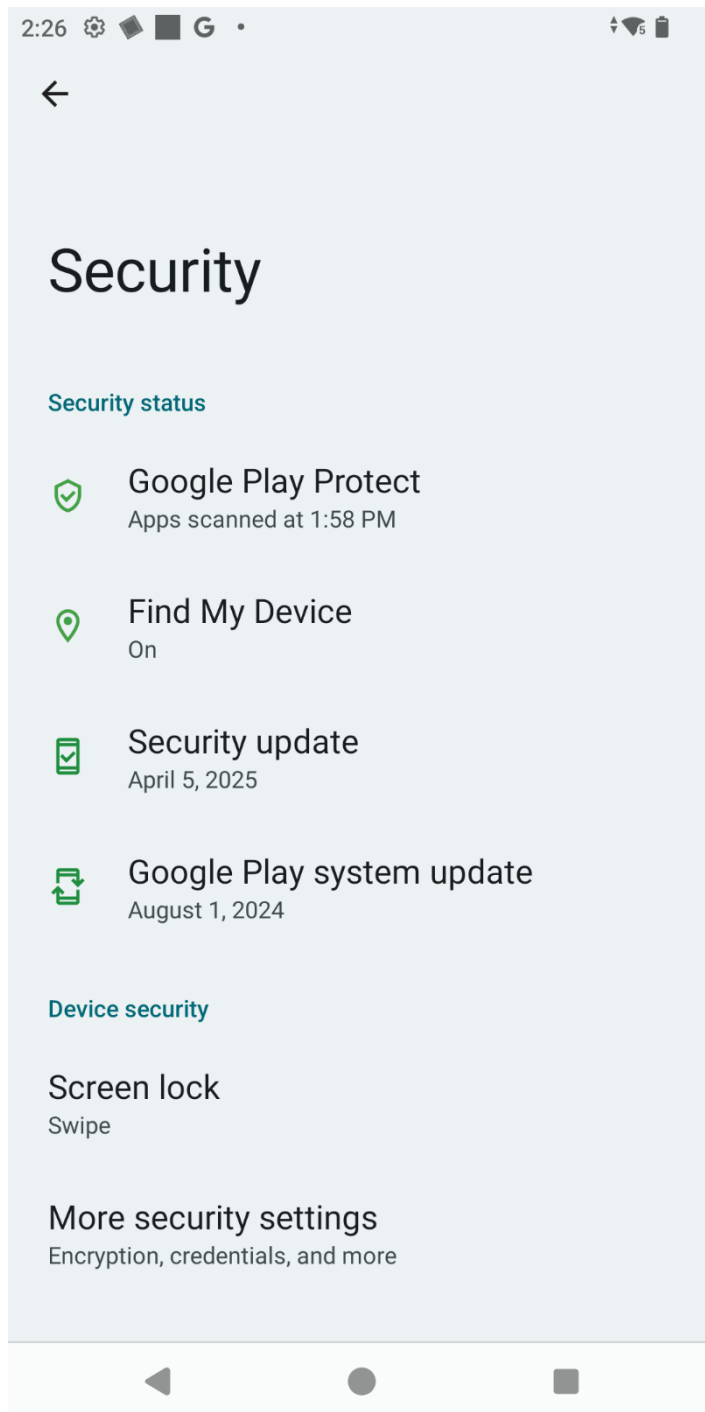

Google play protect

Shows the scan status of Google Play Protect., it indicates "Apps scanned at 1:58 PM," meaning Google Play Protect regularly scans apps on the device to detect potentially harmful software.

Find My Device

Shows the status of the "Find My Device" feature, it indicates "On," meaning this feature is enabled and can be used to locate, lock, or erase the device if lost or stolen.

Security update

Shows the date of the last security update. It indicates "April 5, 2025." It is recommended to regularly check for and install the latest security updates to protect the device from the latest security vulnerabilities.

Google Play system update

Shows the date of the last Google Play system update. It indicates "August 1, 2024." This update is different from Android OS updates and primarily targets Google Play services and related modules.

4.6.2 DEVICE SECURITY

4.6.2.1 SCREEN LOCK

Screen lock

Shows the currently set screen lock type. It indicates "Swipe," meaning the screen is currently unlocked using a swipe gesture. Tapping this allows changing the screen lock method, such as setting a PIN, pattern, or password.

4.7 PRIVACY

Privacy dashboard

Tapping this displays which apps have recently used permissions, such as location, microphone, and camera. This helps understand app behavior and check for any inappropriate permission usage.

Permission manager

you can manage the permissions for each application in detail. You can view different categories of permissions (e.g., contacts, files and media, location, etc.) and configure whether to allow each app to access this data, and when (e.g., only while using the app).

Data sharing updates for location

This option provides updates on how applications share location data, helping users understand and manage their location privacy.

Show password

When this option is turned on, the characters entered are briefly displayed while typing passwords, making it easier for users to check if they have entered them correctly. This feature is currently turned on in the screenshot.

Notifications on lock screen

Configure the notification content displayed on the lock screen. You can choose to show all notification content, hide sensitive content, or not show notifications at all. The current setting is "Show all notification content."

Show media on lock screen

When this option is turned on, the media player remains open on the lock screen for quick resumption of playback, even when the screen is locked. This feature is currently turned on in the screenshot.

Android System Intelligence

This feature provides suggestions based on interaction with people, apps, and content, such as smart replies and contextual awareness. Tap to view or manage related settings.

App content

This option allows or prohibits applications from sending content to the Android system. Enabling this feature may allow for easier information sharing or more convenient features between applications. This feature is currently turned on.

Show Clipboard Access

When this option is turned on, a message notification will appear on the screen when an application accesses text, images, or other content that has been copied. This helps monitor how applications use the clipboard. This feature is currently turned on.

Health Connect

Tapping this takes to Health Connect, a platform for centrally managing health data from different applications. Here, control over which applications can access and share health data is available.

Autofill service from Google

Manage Google's Autofill service, including saved passwords, credit card information, and addresses. When enabled, this allows for quick filling of this

information when needed, but it also involves the security of sensitive personal data, so set it up carefully.

Activity control

Tapping this takes to the Activity controls settings for the Google Account, where a choice of which activities and information to allow Google to save, such as Web & App Activity, Location History, YouTube History, etc., for personalized experiences is available.

Ads

Manage the ad personalization settings on the device. The option to turn personalized ads on or off, as well as reset the advertising ID and manage other related settings, is available.

Usage and Diagnostics

Configure whether to share data about how the device is used and diagnostic information with Google to help improve the Android system. The option to turn this feature on or off is available.

4.8 LOCATION

4.8.1 GO TO "LOCATION" SETTINGS

Step 1. Open the Settings app

- From the Home screen or in the application list, tap Settings.

Step 2. Find the "Location" option

- On the settings page, scroll down, find "Location" and tap to enter.

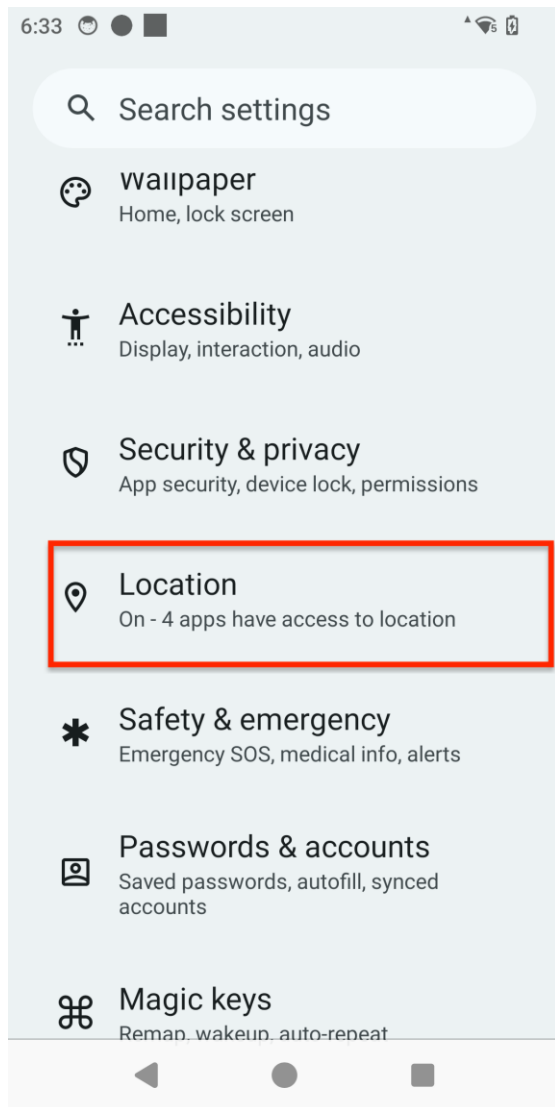

4.8.2 ENABLE OR DISABLE LOCATION

- On the Location settings page, tap the Toggle Switch to turn location services on or off:
 - o On: Allow the app to access your location information.
 - o Off: Prevent apps from accessing your location information.

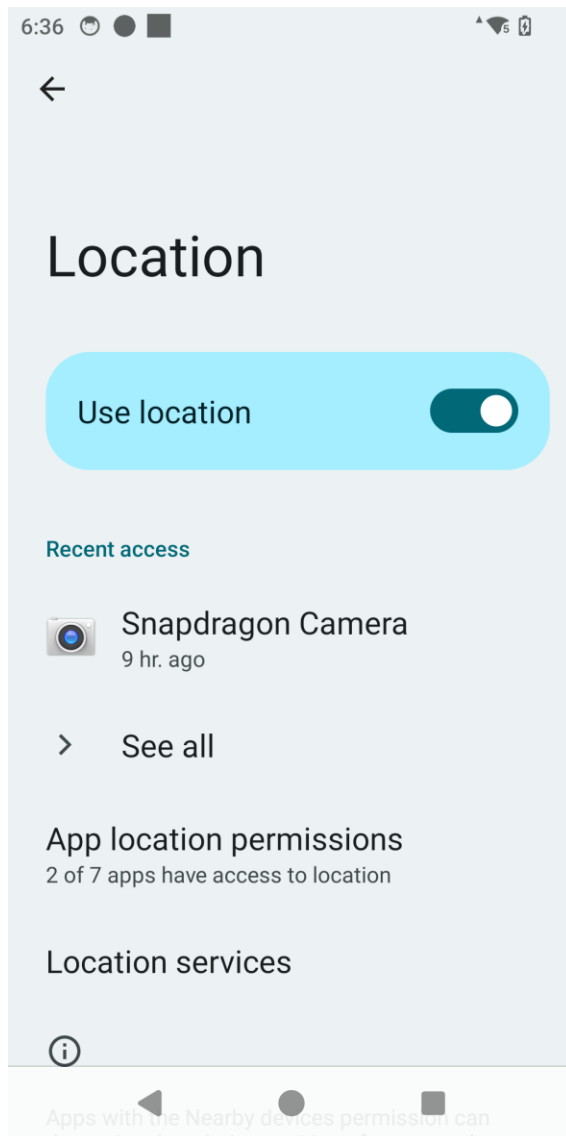

4.8.3 RECENT LOCATION ACCESS MANAGEMENT

On the Location page, scroll down to Recent Location Access.

Here you will see a list showing:

- The name of the application that accessed the most recent location.
- The time the app accessed the location (for example: “5 minutes ago”).

4.8.4 APP LOCATION PERMISSION MANAGEMENT

1. Click App location permissions.
2. Select the app you want to manage.

- "Allow all the time": The application can continue to access location information even when it is running in the background. It is suitable for applications that need to track location (such as driving navigation, health tracking, etc.).
- "Allow only while using the app": The location can be accessed only when the app is open.
- "Ask every time": Ask whether to allow access every time you use it.
- "Never allow" (Deny): prohibit the app from accessing location information.

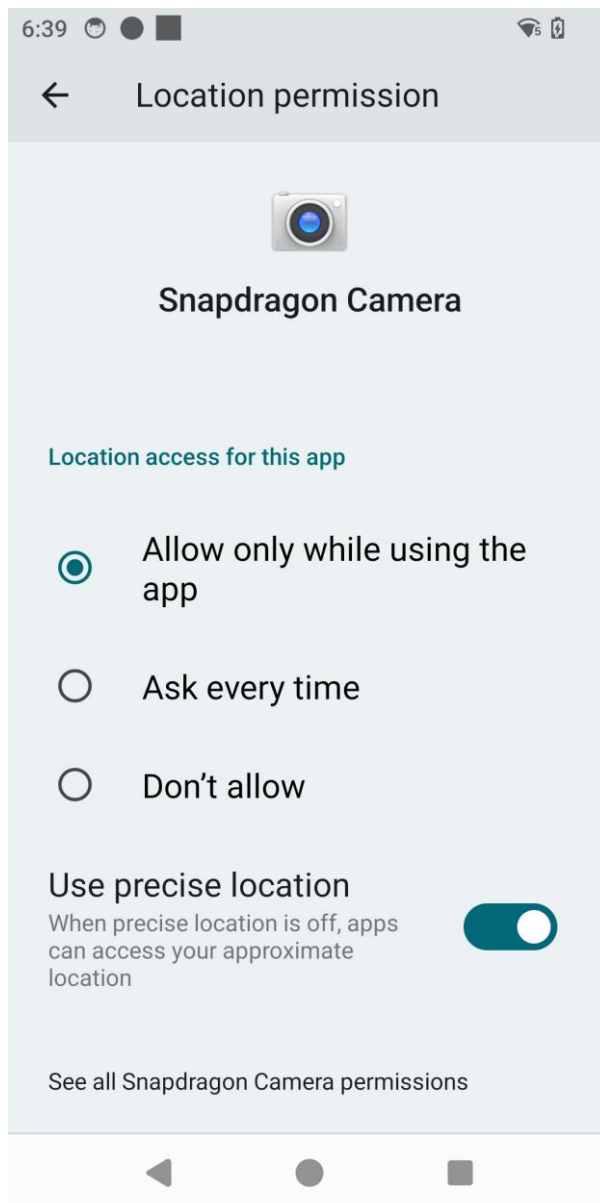

Tip: Some apps (such as Maps, Navigation) may need to enable background location access (Allow all the time) to provide full functionality.

Open Personal Safety: Tapping this will open the "Personal Safety" application, which includes more safety tools and information, such as emergency sharing, call 110 and safety checks.

Medical information: Here, personal name, blood type, allergies, and other medical information can be set up. This information can be helpful to first responders in an emergency, and it may be viewable even when the phone is locked. Currently, it shows "No information," so it is recommended to set this up.

Medical information

Name, Date of birth, blood type, allergies, and other medical information can be set up. This information can be helpful to first responders in an emergency, and it may be viewable even when the phone is locked. Currently, it shows "No information," so it is recommended to set this up.

Emergency contacts

Close friends or family members who can be quickly contacted in an emergency can be set up here. Currently, it shows "No information," so it is recommended to add contacts.

Emergency SOS

Configure quick actions, such as rapidly pressing the power button, to trigger an emergency request for help. This feature is currently "On." Tap to view or change the trigger method and contacts.

Crisis Alerts

After signing into the "Personal Safety" application, alerts for natural disasters or other crisis events may be received. Currently, it shows "Sign in to Personal Safety," indicating that the Personal Safety app needs to be signed into to use this feature.

Emergency Location Service

When making an emergency call, this sends the device's precise location to emergency services. This feature is currently "On."

Emergency Location Service

When making an emergency call, this sends the device's precise location to emergency services. This feature is currently "On."

Earthquake alerts

Receive nearby earthquake alerts to take protective measures early. This feature is currently "On."

Unknown tracker alerts

Receive alerts when an unknown Bluetooth tracker is detected nearby and may be following the user.

Wireless Emergency alerts

Upon receiving a Wireless Emergency Alert (WEA), the device will emit vibrations, play an alert sound, and display an emergency notification

Examples of such alerts include the following:

1. [Earthquake Alert] At approximately 07:38 on January 26, a significant and perceptible earthquake occurred in the southern region. Individuals are advised to be cautious of strong tremors and seek nearby shelter. – Central Weather Bureau
2. [Air Raid Drill] A civil defense exercise is being conducted. Motorists are instructed to reduce speed and pull over safely. The public is advised to follow official guidance and evacuate to the nearest designated shelter.

4.10 PASSWORDS & ACCOUNTS

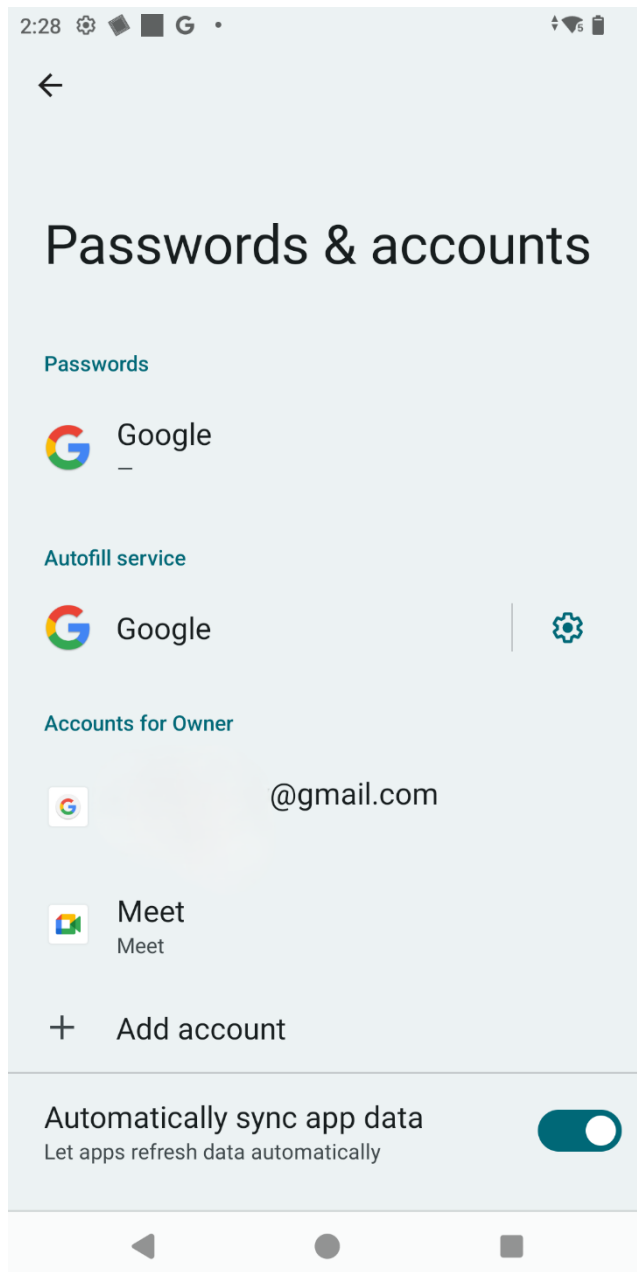

4.10.1 PASSWORD

Google

Tapping this allows viewing passwords saved and synced with the Google Account. It typically lists the accounts and passwords used on different websites and applications. You can view, edit, or delete these stored credentials.

4.10.2 AUTOFILL SERVICE

Google

Shows the currently set autofill service provider on the device. Autofill services can help automatically enter saved information, such as passwords, credit card

details, and addresses, when logging into apps or filling out forms. Tapping the gear icon on the right allows access to detailed autofill settings.

4.10.3 ACCOUNTS FOR OWNER

Google

Shows the primary Google Account logged in on the device for the main user (owner). Tapping this allows managing the account's sync settings, personal information, security settings, etc.

Meet (Meet)

Shows the Meet account logged in on the device for the main user. Meet is Google's video conferencing application, and relevant account information can be viewed or managed here.

+ Add account

Tapping this allows adding other types of accounts to the device, such as email accounts, social media accounts, or other application accounts.

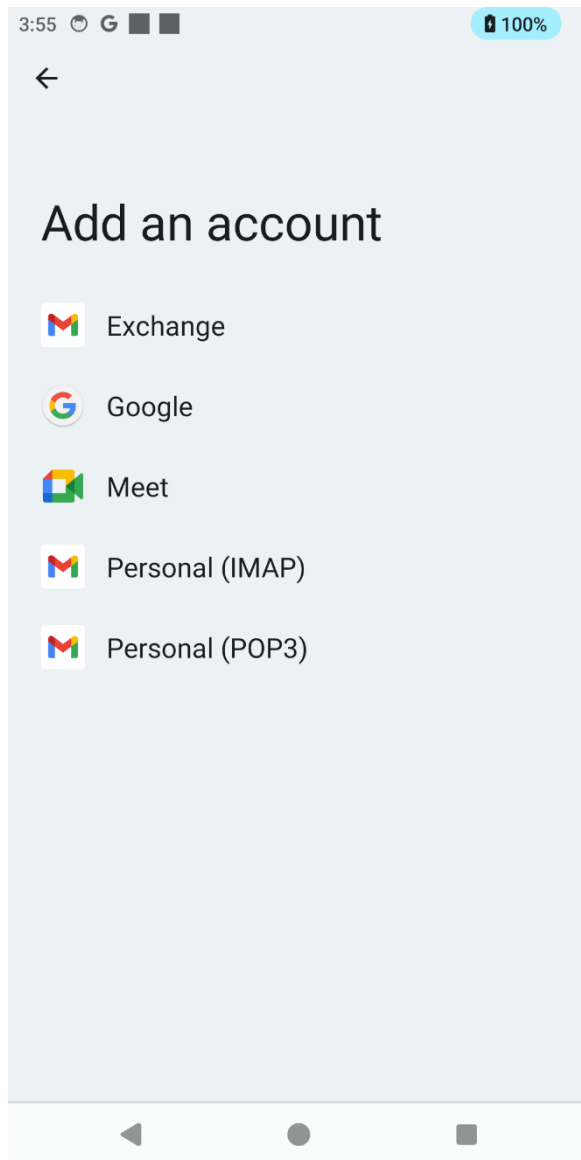

After tapping "Add account" in the "Passwords & accounts" settings, allowing a choice of the account type to add. Here's a brief explanation of each option:

Exchange

Tap this option to add an Exchange account, typically used for work or school email, calendar, and contact synchronization. The relevant server information, username, and password will need to be entered.

Google

Tap this option to add a Google Account. Adding a Google Account allows synchronization of data for Google services such as Gmail, Google Drive, Google Calendar, and Google Photos, and enables the use of the Google Play Store to download applications.

Meet

Tap this option to add a Google Meet account. Meet is Google's video conferencing application. Adding an account enables the use of Meet for video calls and meetings on the device.

Personal (IMAP)

Tap this option to add a personal email account using the IMAP protocol. IMAP allows access to the same emails on multiple devices, and emails are usually kept on the server. The email address, password, and IMAP server settings will need to be entered.

Personal (POP3)

Tap this option to add a personal email account using the POP3 protocol. POP3 typically downloads emails to the device and may delete them from the server. The email address, password, and POP3 server settings will need to be entered.

Tap the corresponding option based on the type of account to add, and then follow the on-screen instructions to enter the required account information and server settings (if necessary). After successfully adding the account, it will be visible in the "Passwords & accounts" settings, where its synchronization settings can be managed.

Automatically sync app data

This option controls whether applications automatically refresh data in the background. When turned on, applications will periodically update information.

4.11 DIGITAL WELLBEING & PARENTAL CONTROL

The "Digital Wellbeing & Parental Controls" page offers tools for monitoring device usage, managing screen time, reducing interruptions, and setting parental controls to ensure a healthy digital experience.

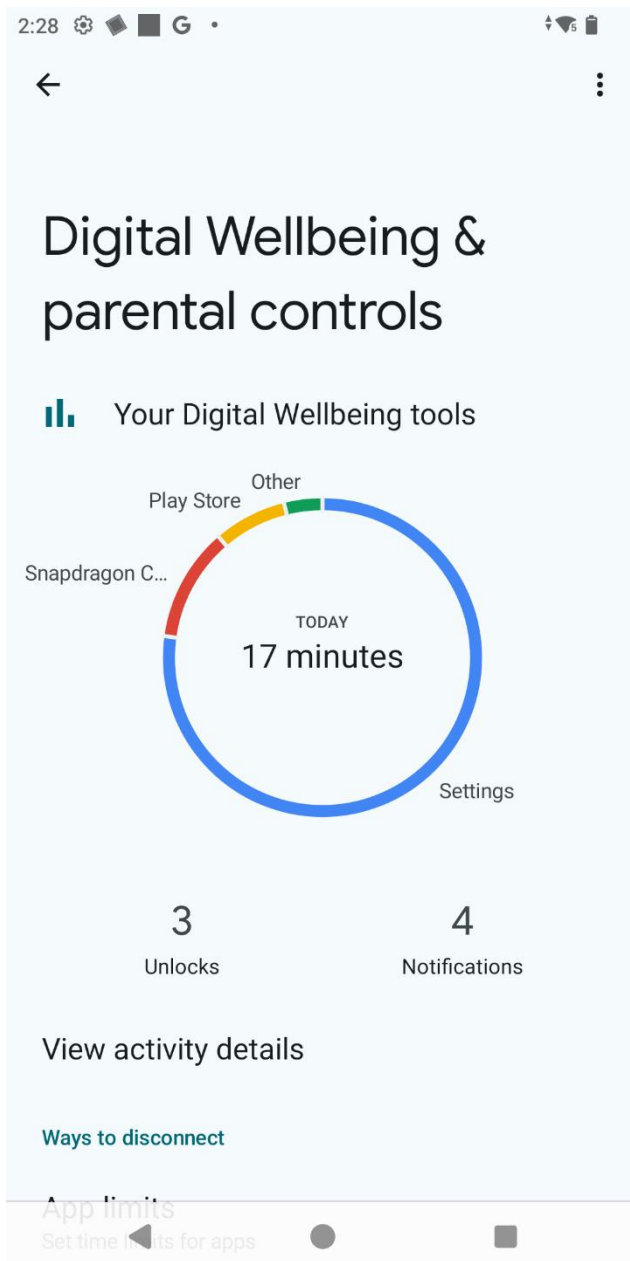

Dashboard

The dashboard displays a daily summary of screen time, highlighting the total minutes spent on the device for the current day.

A circular graph visualizes time spent on individual apps, such as Settings, Snapdragon C..., Play Store, and others.

Additional metrics include the number of device unlocks and notifications received throughout the day.

Key Features

- App timers

Set daily time limits for specific apps to help manage screen time.

- Bedtime Mode

Set daily time limits for specific apps to help manage screen time.

- Focus

Pause distracting apps temporarily to improve concentration.

- Manage Notifications

Customize notification settings to reduce interruptions.

- Do Not Disturb

Silence calls, alerts, and notifications during designated times.

- Heads Up

Enable reminders to take breaks from the screen.

- Show Icon in the App List

Toggle the visibility of the Digital Wellbeing icon in the app drawer.

- Parental Controls

Parental controls can be set up to restrict content, manage privacy settings, and establish screen time rules for a child or teen's Google Account.

The setup process guides the user through selecting appropriate content ratings and configuring usage limits for the device.

How to Set Up Parental Controls

Navigate to the "Digital Wellbeing & Parental Controls" section in the Settings app.

Select "Parental controls" under the Families section.

Tap "Set up parental controls" to begin the configuration process.

Follow the on-screen instructions to choose content restrictions, privacy settings, and screen time rules suitable for the child's or teen's Google Account.

Complete the setup by confirming the selections.

The "Google" settings page provides access to a variety of Google services, including backup, device security, account autofill, payments, sharing, family management, privacy, and connected device options. Services are organized under "Recommended" and "All services" tabs for easier navigation.

Recommended Tab

- Backup

Displays current backup status, including storage usage and backup activity. Management options are available to review or modify backup settings.

- Find My Device

Provides access to the Find My Device app or web service for locating a lost or stolen device. Download links are provided for installation if necessary.

- Autofill

Enables autofill of forms using information saved to a Google Account. The setup process can be continued from this section.

- Google Wallet

Allows tap-to-pay in stores, boarding flights, and more, using the phone. Installation options for Google Wallet are presented if not already set up.

- Quick Share

Facilitates sharing with contacts and updating who can share with the device. Settings can be accessed for further customization.

- Family Group

Offers options to share Google services, storage, and subscriptions with family members. The setup process can be continued from this section.

- What's New

Presents updates and new features for Android devices, such as those released in March 2025.

All Services Tab

- Backup & Restore

Backup: Manage device data backup to Google Drive.

Set up a nearby device: Configure new devices using existing Google account data.

- Kids & Family

Parental controls: Set restrictions and manage content for children's accounts.

- Personal & Device Safety

Find My Device: Locate, lock, or erase a device remotely.

- Device Policy

Set up work profile: Configure a separate profile for work-related apps and data.

- Other

Location Accuracy: Manage settings related to device location accuracy.

- Privacy & Security

Ads: Manage ad personalization preferences.

Personalize using shared data: Control how shared data is used for personalization.

Usage & diagnostics: Allow or restrict sharing of device usage and diagnostic data with Google.

- Autofill & Passwords

Autofill with Google: Manage autofill settings for forms and passwords.

Passkeys and devices: Configure passkeys for passwordless sign-in.

Phone number sharing: Manage sharing of phone numbers for account recovery and other services.

SMS verification codes: Enable or disable automatic SMS code retrieval for verification.

- Settings for Google Apps

Search, Assistant & Voice: Manage settings for Google Search, Assistant, and voice services.

- Connected Devices & Sharing

Cast options: Configure casting to supported devices.

Cross-device services: Manage features that work across multiple devices.

Devices: View and manage devices linked to the Google account.

Quick Share: Adjust sharing settings for sending and receiving files.

Thread networks: Manage connectivity for Thread-enabled smart home devices.

This guide summarizes the main functions and navigation structure of the "Google" settings page, supporting efficient management of Google services, privacy, security, and connected device features on Android.

4.13 SYSTEM

Language

Configure the device's system language, app language preferences, and languages for speech input. Languages can be added, removed, or ordered according to personal needs.

Keyboard

Adjust the settings for the on-screen keyboard, such as input methods, auto-correction, text prediction, etc. Installed keyboard applications and related tools can also be managed here.

Gestures

Set up and customize the device's navigation methods, such as using swipe gestures to go back, to the home screen, or to open recent applications and open the Camera. Some advanced gesture features can also be configured here.

Date & Time

Set the device's date, time, and time zone. Automatic or manual setting options are available, as well as adjustments for the time display format.

Backup

Manage the device's data backup settings. You can view the last backup time, configure a backup account, and choose the types of data to back up to ensure data security.

Software Update

Check for and install the latest updates for the Android operating system. Keeping the system updated helps improve the device's security, stability, and performance. Currently displayed as "Updated to Android 14."

Multiple Users

Set up multiple user accounts on the device. Each user has independent applications, data, and settings, making it convenient for multiple people to share the same device. Currently displayed as "Signed in as Owner."

Developer options

This is an advanced settings menu typically used by developers, containing various options such as USB debugging, bug reports, animation scaling, and more. General users should exercise caution when operating settings in this menu.

Reset Options

Provides various ways to reset the device, including resetting Wi-Fi, mobile network, and Bluetooth; resetting app preferences; and performing a factory data reset (erasing all data). Be sure to understand the implications before performing any reset operation.

System update history

This page shows the history of all system software updates. It displays the firmware version, along with the date and time of each update, providing a clear record of changes and resets performed on the device.

ExLogger

Specific application related to system logging services, used for diagnosing or recording system behavior.

4.14 MAGIC KEYS

Please refer to 2.2 Product Details for the location of the buttons.

Scan key (left) / Scan key (right) / Push-to-talk key (Program key) supports Remap keys & shortcuts and Wakeup keys. (As shown in the picture)

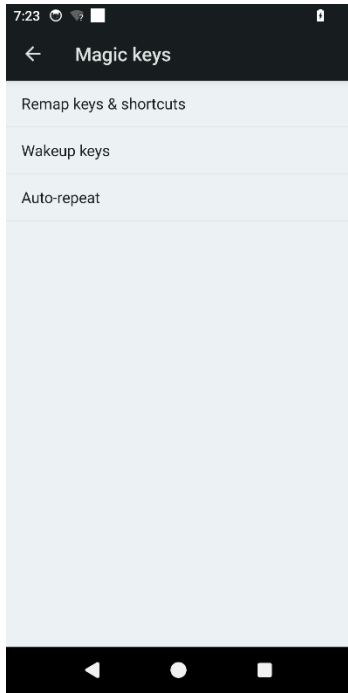

1. Remap keys & shortcuts

On this page, click the desired remap key

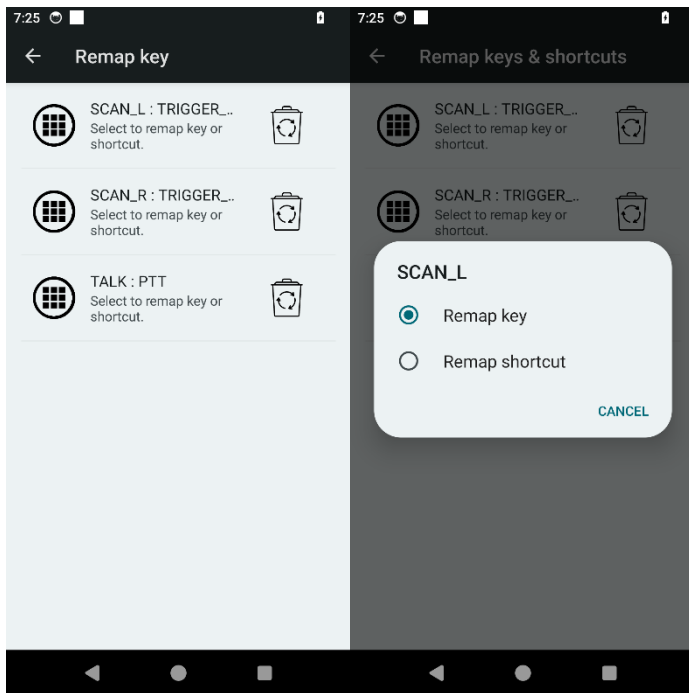

Step 1. Remap key

On this page, select which function to remap to.

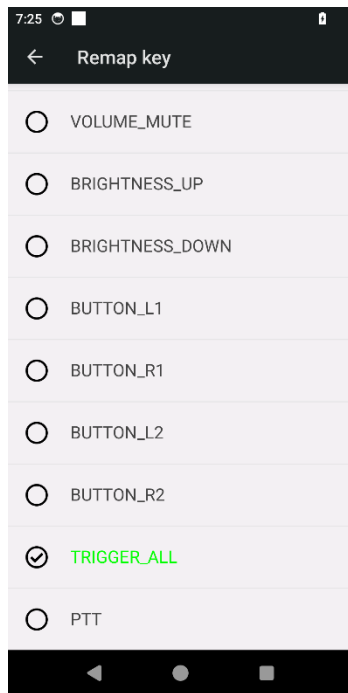

Step 2. Remap shortcut

On this page, select the shortcut to which you want to remap.

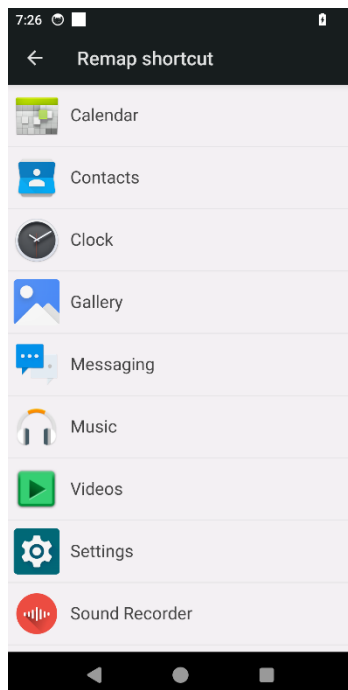

2. Wakeup keys

After checking this button, the user can wake up the device.

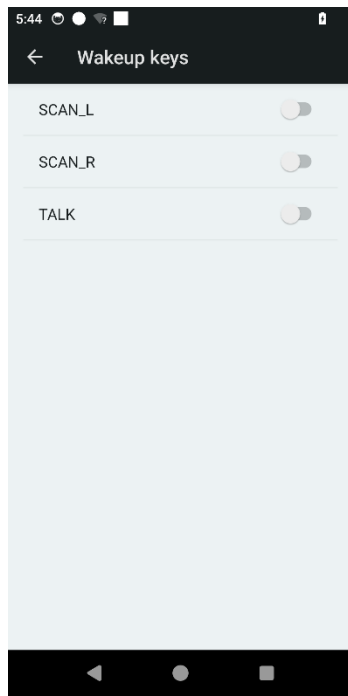

3. Auto-repeat

After checking, a long press can send the keycode repeatedly.

5. CONNECTION

5.1 INTERNET

How to Check if Your Phone is Using 4G or 5G

Method 1: Check the Status Bar

Look at the top of your screen, in the status bar (where the time, battery, and signal icons are). You should see a small icon near the signal bars, such as:

- 4G / LTE – means you're connected to a 4G network.
- 5G – means you're on a 5G network.

Method 2: Open the Settings app.

1. Go to "Network & Internet".
2. Tap on "Internet".
3. It will show you what your phone is currently connected to.

How to Turn on Airplane Mode

Method 1: Using Quick Settings

1. Swipe down from the top of the screen to open the notification shade.
2. Swipe down again (if needed) to fully expand the Quick Settings panel.
3. Look for the Airplane Mode icon.
4. Tap it to turn it on. Your mobile data, Wi-Fi, and Bluetooth will be turned off automatically.

Method 2: Using Settings

1. Open the Settings app.
2. Tap "Network & Internet".
3. Toggle "Airplane mode" on.

How to Turn on Data Saver

1. Open the Settings app.
2. Tap "Network & Internet".
3. Tap "Data Saver" (you might need to scroll down).

4. Toggle the switch on.

This feature restricts background data usage to help you save mobile data. Apps that are not in active use won't be allowed to use data in the background.

How to Add an eSIM

Method 1: Add eSIM Using a QR Code

1. Open the Settings app.
2. Tap "Network & Internet".
3. Tap "SIMs".
4. Tap "+ Add SIM".
5. Tap "Download eSIM".
6. Choose Scan QR code.
7. Use your phone to scan the QR code provided by your carrier.
8. Tap the check icon to download eSIM.

Method 2: Add eSIM Manually (if QR code isn't available)

1. Follow steps 1–5 above. Instead of scanning a QR code, choose Enter details manually.
2. Input the SM-DP+ address and activation code provided by your carrier.
3. Tap the check icon to download eSIM.

How to Make Emergency Calls Without a SIM Card

Even if your phone doesn't have a SIM card, you can still make emergency calls.

Method 1: From the Lock Screen

1. Press the Power button to turn on the screen.
2. On the lock screen, tap "Emergency".
3. You can now dial an emergency number like:
 - 112 (common in Europe and other countries)
 - 911 (USA, Canada)
 - Or your country's emergency number.

- Press the Power button to turn on the screen.
4. Press the call button.

Method 2: From the Phone App

1. Open the Phone app.
2. Dial the emergency number (e.g., 112 or 911).
3. Press the call button.

5.2 Wi-Fi

Wireless Local Area Networks

A Wireless Local Area Network (WLAN) is a type of network that allows devices to connect and communicate wirelessly within a limited area, such as a home, office, or building. Unlike traditional wired networks that require physical cables, WLANs use radio waves to transmit data, enabling greater mobility and convenience for users.

WLANs are commonly used in environments where flexibility and easy access to the network are essential. They are powered by access points (APs), which act as the central hubs for wireless communication, connecting devices like laptops, smartphones, and tablets to the network. The Wi-Fi technology is the most widely used standard for WLANs, providing both convenience and speed for everyday internet and network usage.

To ensure secure communication, WLANs offer various security protocols like OPEN, WPA2, and WPA3, which protect the network from unauthorized access and data breaches. Whether for home use or enterprise applications, WLANs have become an integral part of modern networking by offering wireless convenience without sacrificing the speed and functionality of traditional wired networks.

To set up a **Wireless Local Area Network (WLAN)**, follow these key steps:

1. Refer to Infrastructure Documentation:
Consult the documentation provided with your network infrastructure components, such as access points (APs), switches, and Radius servers. This documentation will guide you through the process of setting up and configuring each device to ensure they work together to create a functional WLAN.

2. Configure WLAN Security:

Once the infrastructure (APs, switches, etc.) is set up, configure the network to enforce the chosen WLAN security scheme. This may include options like WPA2, WPA3, or OPEN, depending on the level of security required for your environment.

The infrastructure must be set up to match the selected security settings, and the security protocols should be applied consistently across the network to ensure protection from unauthorized access.

3. Device Configuration:

After securing the network infrastructure, use the **Network & internet** settings on your device to configure it to match the security settings of the network.

This may involve selecting the appropriate Wi-Fi network, entering a password or security credentials, and ensuring that your device uses the correct **security protocol** (such as WPA2 or WPA3) as set by the network infrastructure.

Following these steps will ensure that both the network infrastructure and your device are properly configured to work together securely and efficiently on the WLAN.

The supported Wi-Fi security types include:

1. **Open (No Authentication)**: Connects to unsecured networks without requiring a password.
2. **WPA2 (Wi-Fi Protected Access 2) - PSK and Enterprise**: Provides stronger data protection and network access control. The Enterprise mode uses Extensible Authentication Protocol (EAP) methods such as EAP-TLS, EAP-TTLS, and PEAP for authentication.
3. **WPA3 (Wi-Fi Protected Access 3) - Personal and Enterprise**: The latest standard offering enhanced security features.
WPA3-Personal: Replaces the pre-shared key (PSK) method with Simultaneous Authentication of Equals (SAE), providing stronger protection against password guessing attacks.
WPA3-Enterprise: Offers enhanced authentication and encryption methods, including an optional 192-bit security mode for sensitive environments.
4. **Wi-Fi Enhanced Open (Opportunistic Wireless Encryption - OWE)**: Provides encryption and privacy on open, non-password-protected networks, enhancing security in public Wi-Fi environments.

Connecting to a Wi-Fi Network

1. Open **Settings**.

2. Open **Network & Internet > Internet**.
3. Choose your Wi-Fi name.
4. If it asks, type the password.
5. When it says **Connected**, you're online!

Removing a Wi-Fi Network

1. Open **Settings**.
2. Open **Network & Internet > Internet**.
3. Scroll down and tap **Saved networks**.
4. Tap the network you want to remove.
5. Tap **Forget**.

WLAN Configuration

This section provides information on configuring a Wi-Fi Network.

1. Open **Settings**.
2. Tap **Network & Internet > Internet**.
3. Turn Wi-Fi ON.
4. Your device will search for available networks and show them.
5. Scroll and select the Wi-Fi network you want to connect to.
6. If the network is **open** (no password), it will connect automatically. For others, a pop-up will appear.
7. For **WPA/WPA2, WPA3** networks, enter the password and tap **Connect**.
8. For **WPA/WPA2/WPA3 Enterprise**, you may need to:
 - Choose an **EAP method** (like PEAP or TLS).
 - Enter any required details (certificate, domain, etc.).

Manually Adding a Wi-Fi Network

1. Open **Settings**.
2. Tap **Network & Internet > Internet**.
3. Turn Wi-Fi ON.
4. Scroll down and tap **Add network**.
5. Type the **Network name** (SSID).
6. Choose the **security type** (e.g., None, WPA2, WPA3, etc.).
7. If security is **None** or **Enhanced Open**, tap **Save**.
8. If security is **WPA/WPA2**, or **WPA3**, enter the **password** and tap **Save**.
 - ◆ For **WPA/WPA2/WPA3 Enterprise**:
 - Choose an **EAP method** (like PEAP or TLS).
 - Enter the necessary details (certificates, domain, etc.).
 - ◆ To connect to the saved network, touch and hold the network name and tap **Connect**.

Configuring for a Proxy Server

1. Open **Settings**.
2. Tap **Network & Internet > Internet**.
3. Turn Wi-Fi ON.
4. Select and tap your **Wi-Fi network**.
5. Tap **Advanced options**.

6. Tap **Proxy** and choose **Manual**.
7. Enter the **Proxy hostname** (server address).
8. Enter the **Proxy port** (port number).
9. In **Bypass proxy for**, add websites that shouldn't use the proxy (separate with commas).
10. Tap **Save** or **Connect**.

Configuring the Device to Use a Static IP Address

1. Open **Settings**.
2. Tap **Network & Internet > Internet**.
3. Turn Wi-Fi ON.
4. Select your **Wi-Fi network**.
5. Tap **Edit** (to modify network settings).
6. Tap **Advanced options**.
7. Tap **IP settings** and select **Static**.
8. Enter your **IP address**.
9. If needed, enter the **Gateway address**.
10. If needed, enter the **Network prefix length**.
11. If needed, enter **DNS 1** and **DNS 2** addresses.
12. Tap **Save** or **Connect**.

Wi-Fi Preferences

1. Open **Settings**.
2. Tap **Network & Internet > Internet**.
3. Scroll down and tap **Network preferences**.
4. From here, you can:
 - **Turn on Wi-Fi automatically**: Wi-Fi will reconnect when near saved networks.
 - **Notify for public networks**: Get notified when a good public Wi-Fi is nearby.
 - **Install Certificates**: Tap to install certificates.
 - **Wi-Fi Direct**: See a list of devices for direct Wi-Fi connection.

Wi-Fi Direct

1. Open **Settings**.
2. Tap **Network & Internet > Internet > Advanced > Wi-Fi Direct**. Your device will start searching for nearby Wi-Fi Direct devices.
3. Under **Peer devices**, tap the other device's name.
4. On the other device, select **Accept**.

Once connected, both devices will show each other in the Wi-Fi Direct list.

5.3 BLUETOOTH

1. On the Home screen, swipe down or tap the App Drawer icon to display all installed apps.
2. In the app drawer, find and tap the Settings icon  to enter the Settings menu.
Select Settings
3. Select the connected device

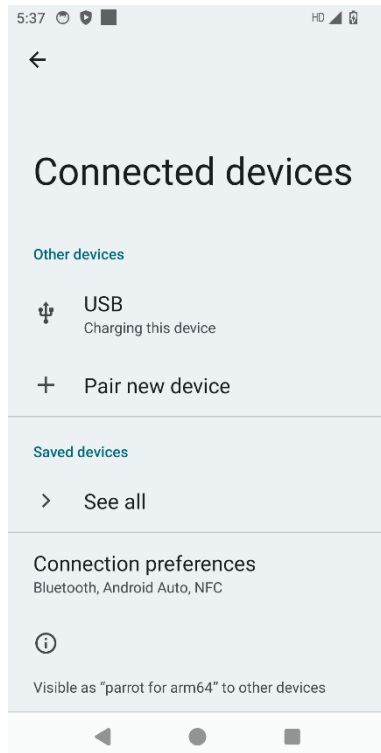

4. Select Connection Preferences
Note: If you choose to pair new device, please proceed to step 7
5. Choose Bluetooth

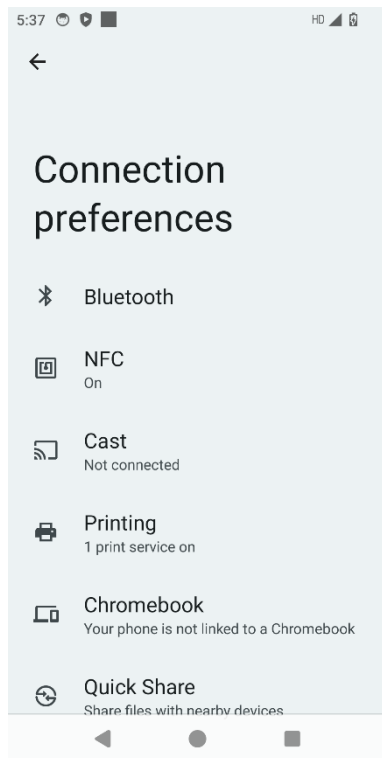

6. Enable Bluetooth and choose pair new device
Note. Default is disable

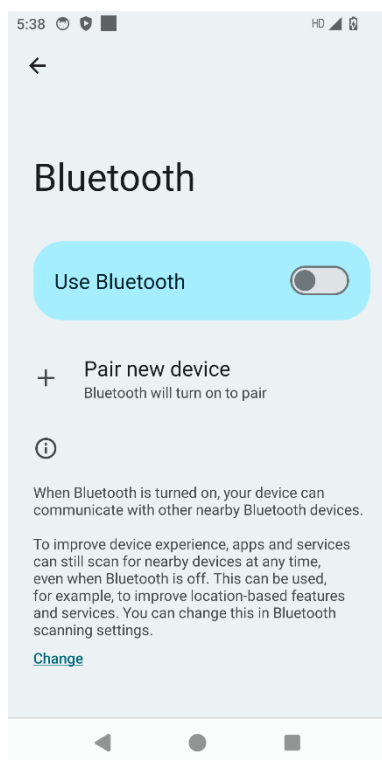

7. You can choose the device to be connected in available device list

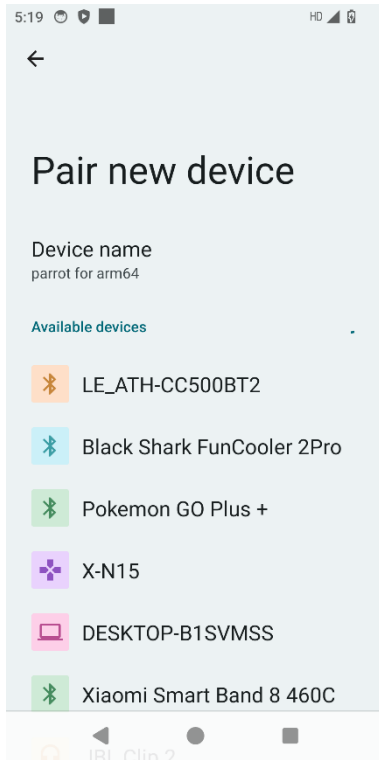

8. Pair the new device

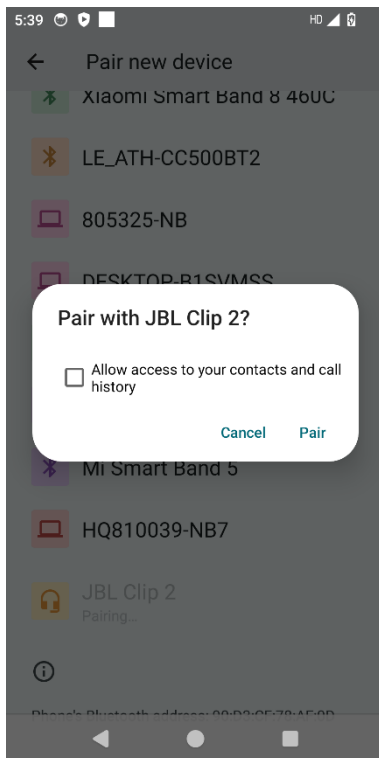

9. You can find the connected device list

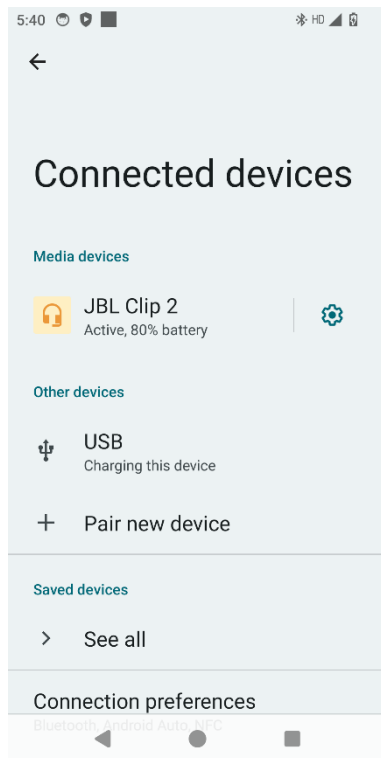

5.4 NFC

NFC is a short-range wireless connection technology standard that enables secure transactions between card readers and contactless smart cards.

This technology is based on ISO/IEC 14443 type A and B, ISO/IEC 15693 and FeliCa standards.

This device supports the following operating modes:

- Card reader mode
- Card emulation mode.

Using NFC, the device can have the following applications:

- Read contactless cards such as contactless tickets, ID cards and e-passports.
- Read and write information to contactless cards (such as SmartPosters or tickets) and devices with NFC interface (such as vending machines).
- Read information from supported medical sensors.
- Pair with supported Bluetooth devices such as printers, ring scanners and headsets.
- Simulate contactless cards such as payment cards, tickets or SmartPoster.

The NFC of RC40 is located on the top of the device, as shown in the blue box in the figure below.

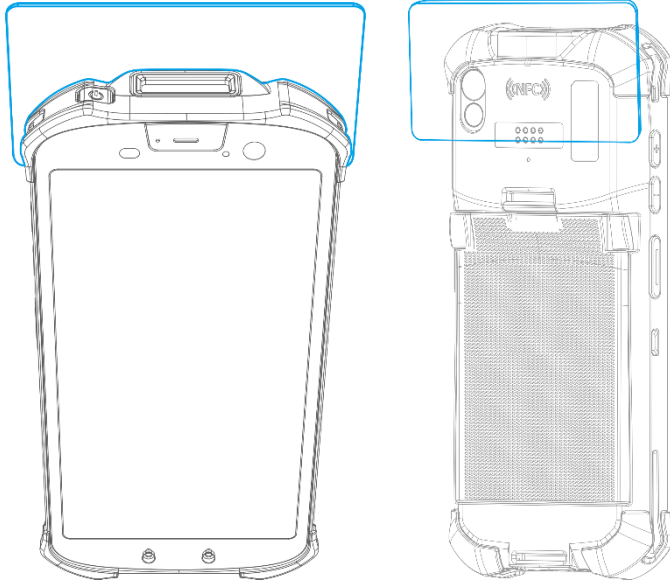

6. APPLICATION DEPLOYMENT

6.1 ABOUT EZCLONE

EZClone is a workstation to help you to deploy / Configure a handful or hundreds of devices with a quick scan of a barcode

6.1.1 DOWNLOAD





You can download the EZClone Workstation by [link](#) here.

Supported Platforms	Workstation Tool, Windows 7 and newer
Supported Devices	RC40; Android 14 and later
Software Capabilities	Connect your device to network, Configure device settings and security, Perform OS updates, Install and execute applications, Wipe and reset the device, manage mobile profiles, Managing device Wi-Fi, Cellular, Hotspot, Bluetooth

6.1.2 INSTALLATION

Whenever a new version is released, the package includes two files for installation (see below). Double-click any file for the next stage.

 EZClone Workstation.msi	2025/1/17 下午 04:01	Windows Installer 封裝	28,726 KB
 setup.exe	2025/1/17 下午 04:01	應用程式	553 KB

The installation Wizard will guide you to the following steps

Step 1

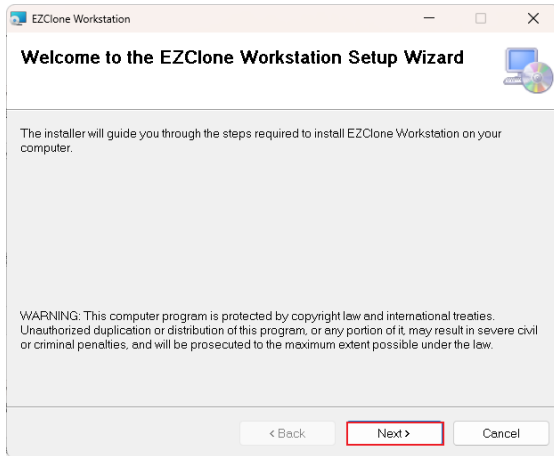

Step 2

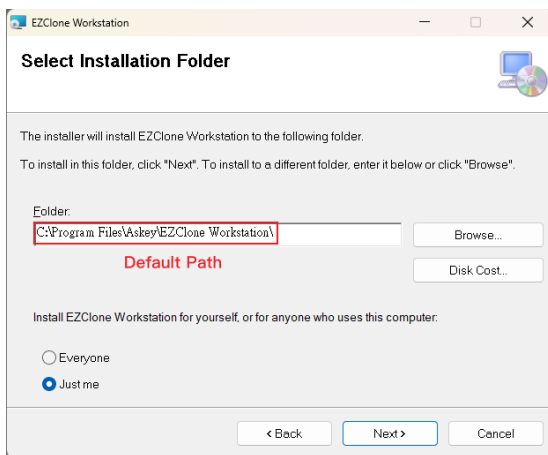

Step 3

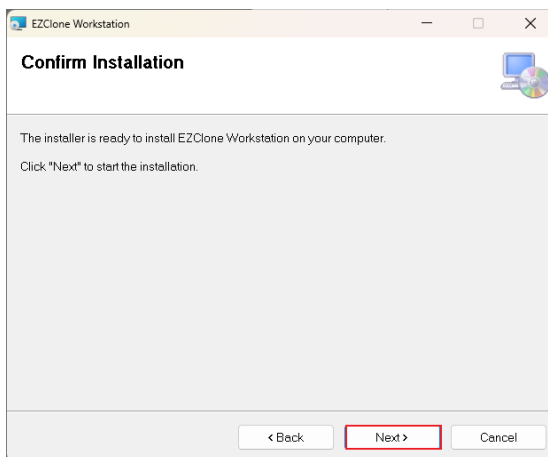

Step 4

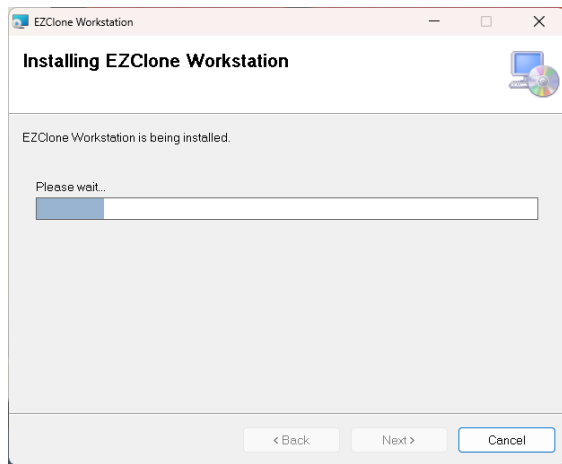

Step 5

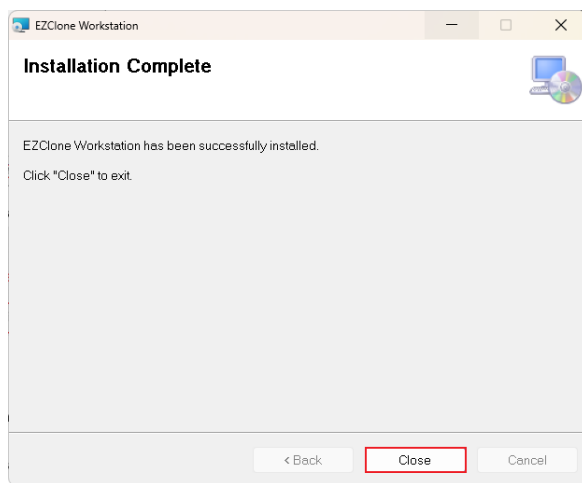

You can find the main program and uninstaller in the program menu, shortcut in the Desktop.

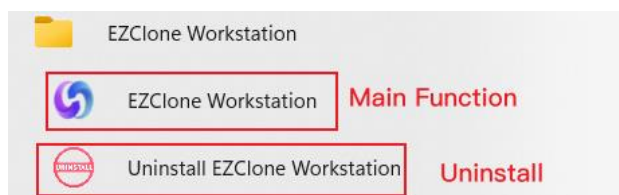

6.1.3 MAIN FUNCTION

Currently, the main function has 8 navigation pages for use.

- (1) Settings
- (2) Device Reset
- (3) Provisioning
- (4) QR Codes
- (5) Export
- (6) Import
- (7) Theme

(8) About

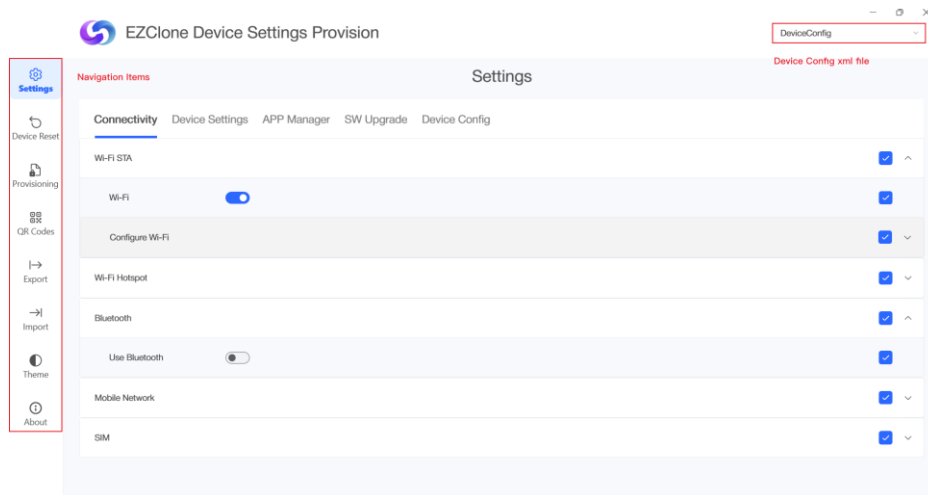

Introduce all the resources files under <Your Installation Path>\Resources

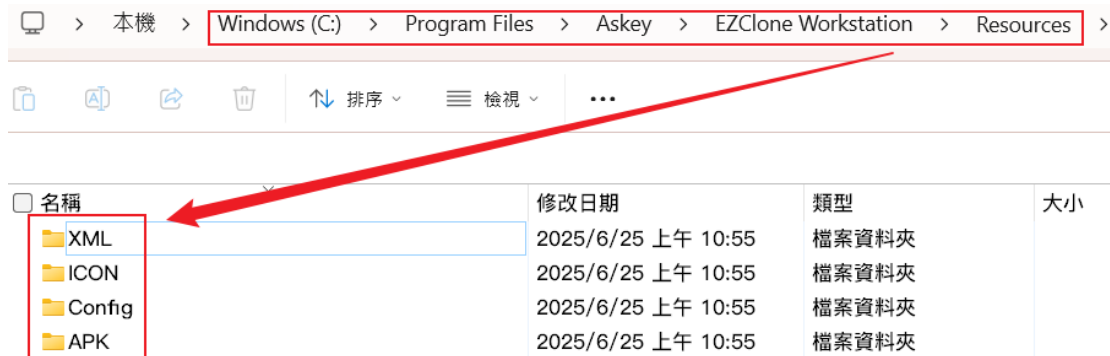

Describe folders for each type

- (1) APK : Put all the apk files
- (2) Config : Put config files / HTTP(s) server / Time Zone List related files
- (3) XML : Put device control function file organized with xml format
- (4) ICON: Put icon files

The rightmost field in the title bar is your current device config file.

Find device config files under C:\Users\[YOUR ACCOUNT]\AppData\Roaming\EZClone\XML



6.1.4 SETTINGS PAGE

The content in the Settings page comes from a certain DeviceConfig xml file which you select.

(A) Tab – Switch between categories

(B) Function – Control values for each item

(C) CheckBox – Function inclusion for QR code source

(D) Expander – Expandable or not

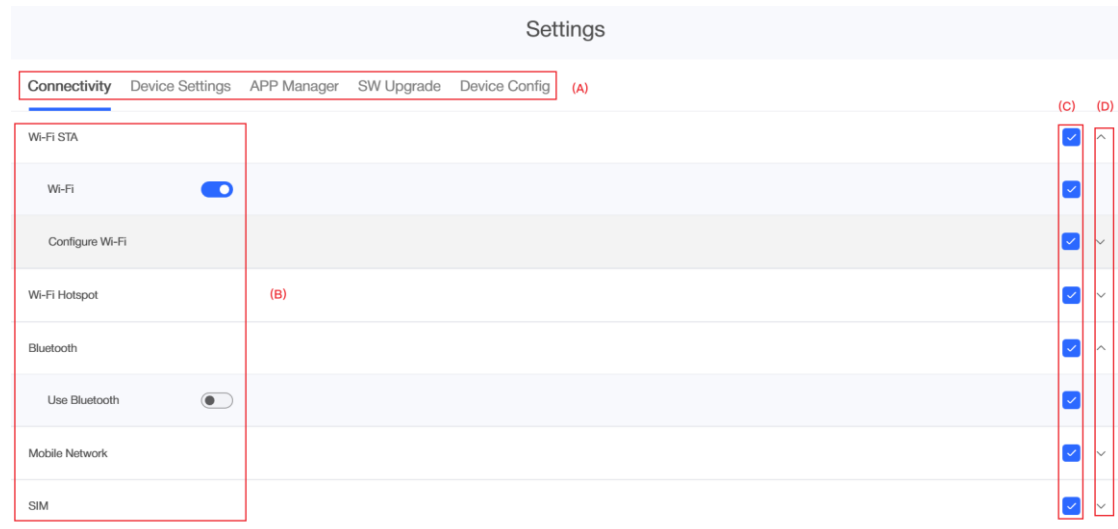

The mechanism to the checkbox:

Classify level 1 category ...(A)

Classify level 2 category / function ...(B)

Classify content function ...(C)

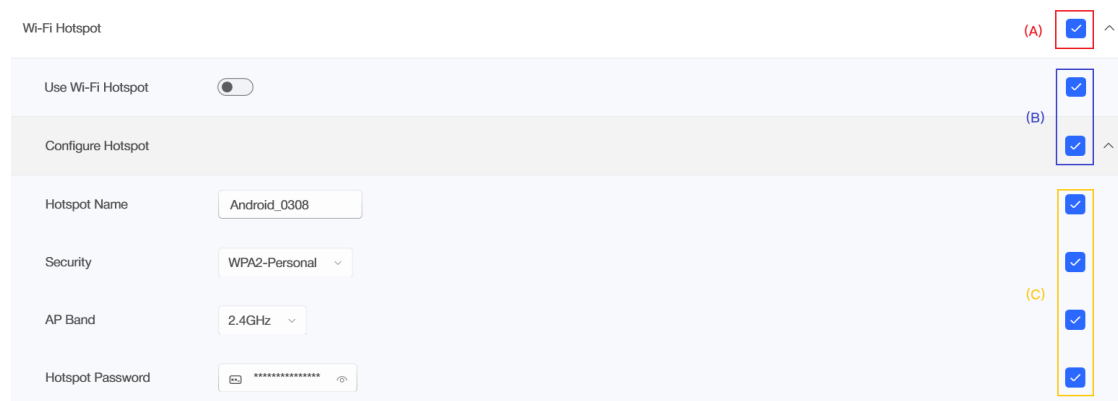

In the example, [Wi-Fi Hotspot] includes [Use Wi-Fi Hotspot] and [Configure Hotspot].

[Configure Hotspot] includes [Hotspot Name] [Security] [AP Band] and [Hotspot Password].

Case 1: If [Wi-Fi Hotspot] is checked.

[Use Wi-Fi Hotspot] [Configure Hotspot] [Hotspot Name] [Security] [AP Band] [Hotspot Password] are also checked.

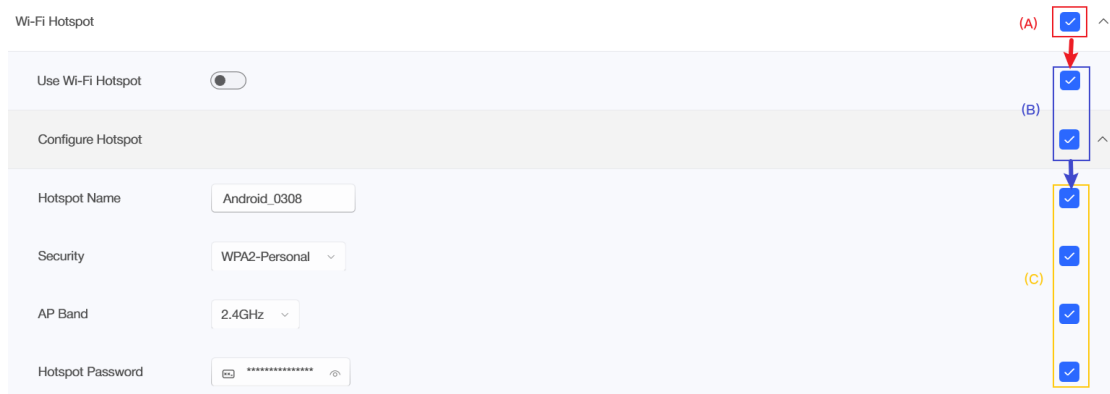

Case 2: If [Wi-Fi Hotspot] is unchecked.

[Use Wi-Fi Hotspot] [Configure Hotspot] [Hotspot Name] [Security] [AP Band] [Hotspot Password] are unchecked.

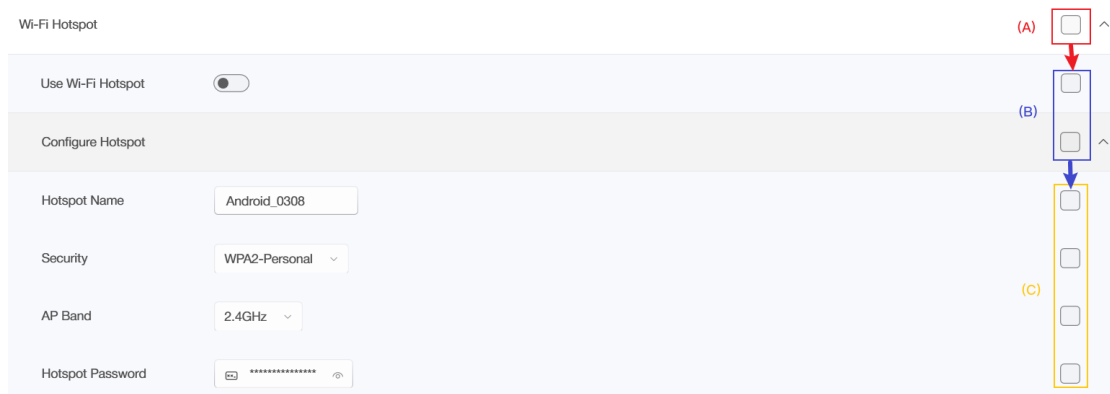

Case 3: If [Use Wi-Fi Hotspot] is checked and [Configure Hotspot] is unchecked.

[Wi-Fi Hotspot] Is partially checked.

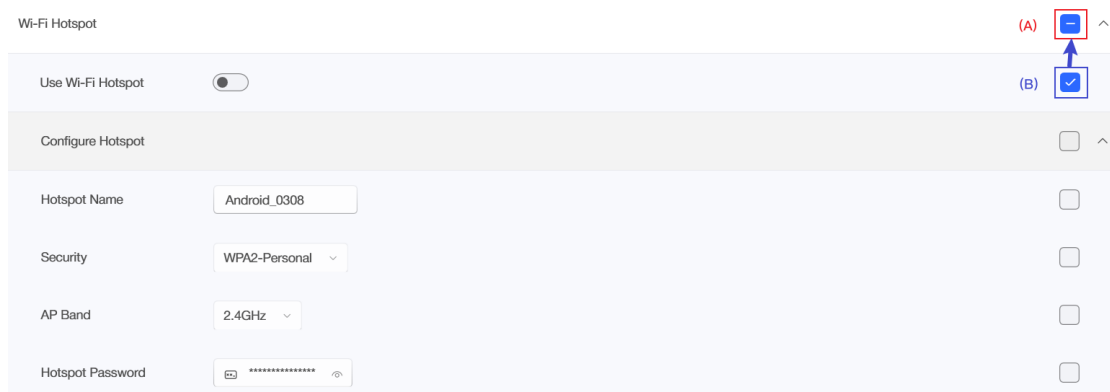

Case 4: If [Use Wi-Fi Hotspot] is unchecked and [Configure Hotspot] is checked.

[Wi-Fi Hotspot] Is partially checked, [Hotspot Name] [Security] [AP Band] [Hotspot Password] are checked.

Wi-Fi Hotspot

(A) [Collapse]

Use Wi-Fi Hotspot

Configure Hotspot (B) [Expand]

Hotspot Name: Android_0308

Security: WPA2-Personal

AP Band: 2.4GHz

Hotspot Password: [Masked]

(C) [Expand] [Checked] [Checked] [Checked] [Checked]

6.1.5 DEVICE RESET PAGE

All the reset items are configured here. After that, click button to generate QR code

EZClone Device Settings Provision

Settings

Device Behavior

Reboot Device

APN Reset

Wi-Fi Reset

Factory Reset

Generate Reset QR Code

6.1.6 PROVISIONING PAGE

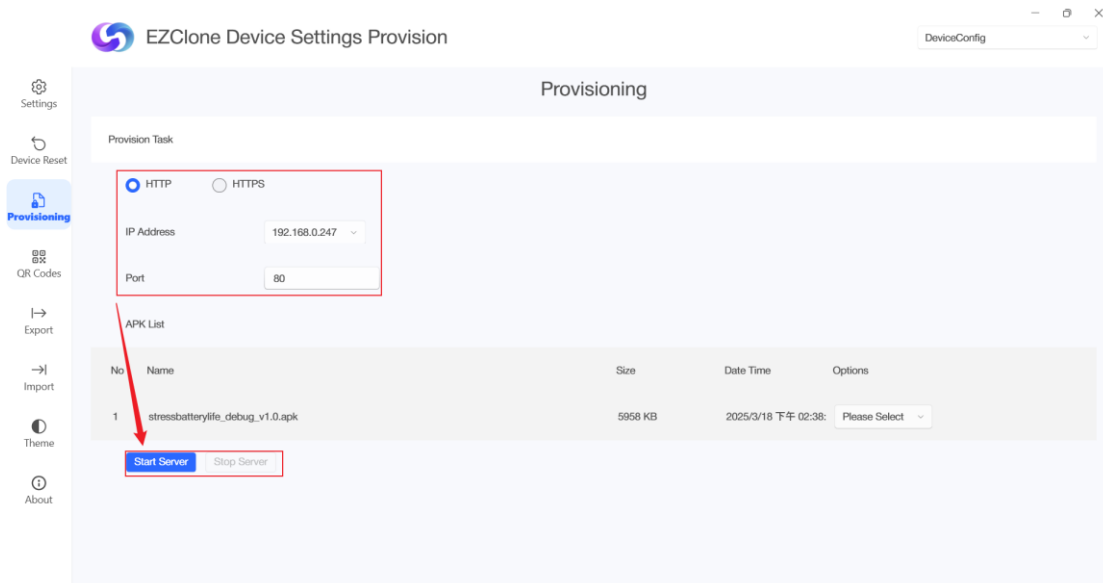

Select HTTP or HTTPS server to start for device to pull QR Code data.

The IP Address and Port can be changed to fit your needs

APK List displays all your APK files selected by Import Page->Choose File->Import File.

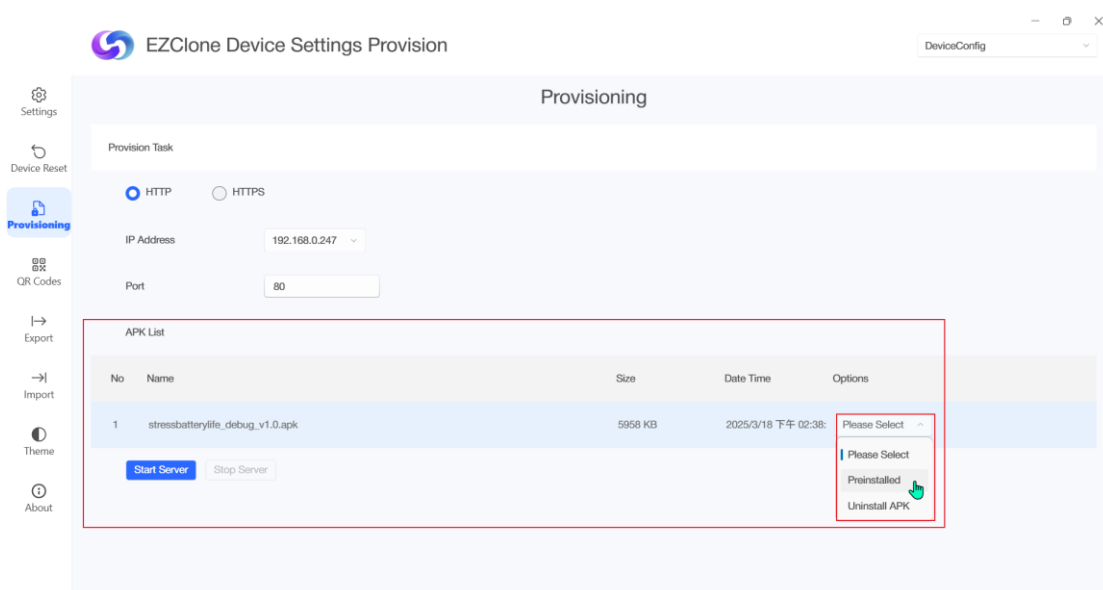

For APKs type, there are Preinstalled and Uninstall APK to select in the option field.

This is the action to perform from the EZClone Workstation server to your device.

6.1.7 QR CODES PAGE

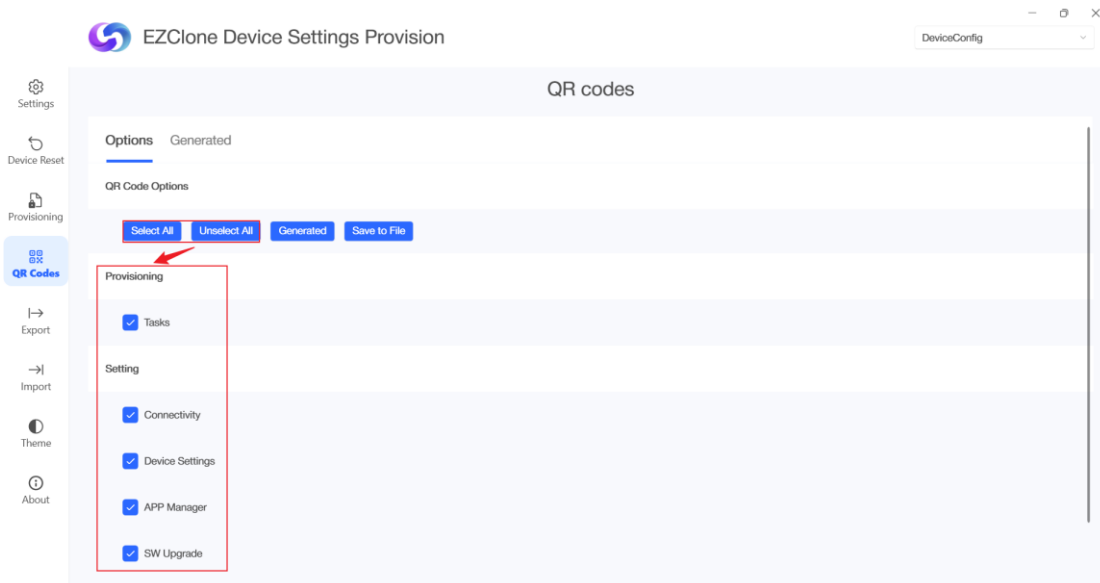

In the Options tab, buttons [Select All] and [Unselect All] control whether the Provisioning and Setting items exist in the current device config or not.

Partially clicking the checkbox by manual is often used, button [Generated] is used to generate barcode image based on the selection.

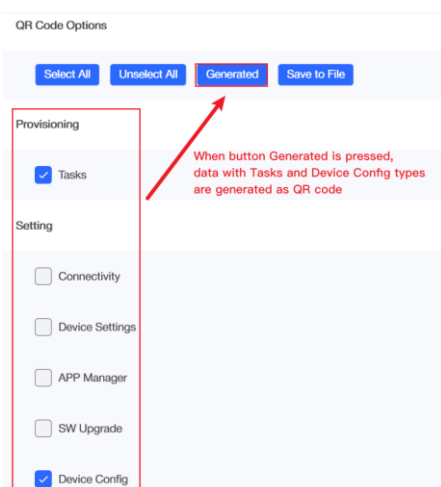

Button [Save to File] is used to save your config file to C:\Users\[YOUR ACCOUNT]\AppData\Roaming\EZClone\XML

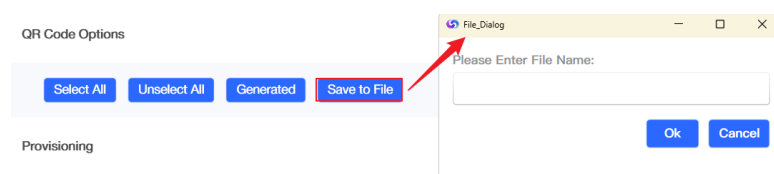

Generated tab is used to view barcode (D).

Control slider (C) to resize the barcode image, actual size is observed in text (B).

Currently there is only 1 barcode marked as number 1 in area (A).

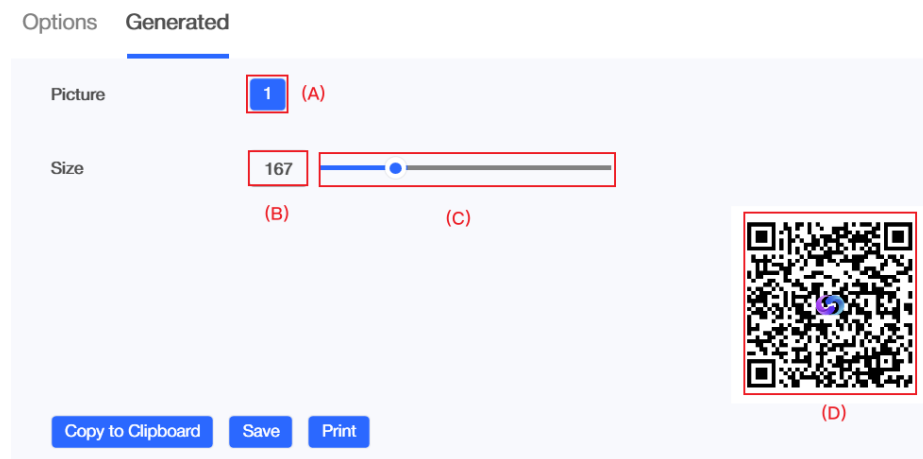

If the data is too large, QR code is generated for downloading the json file when scanning.

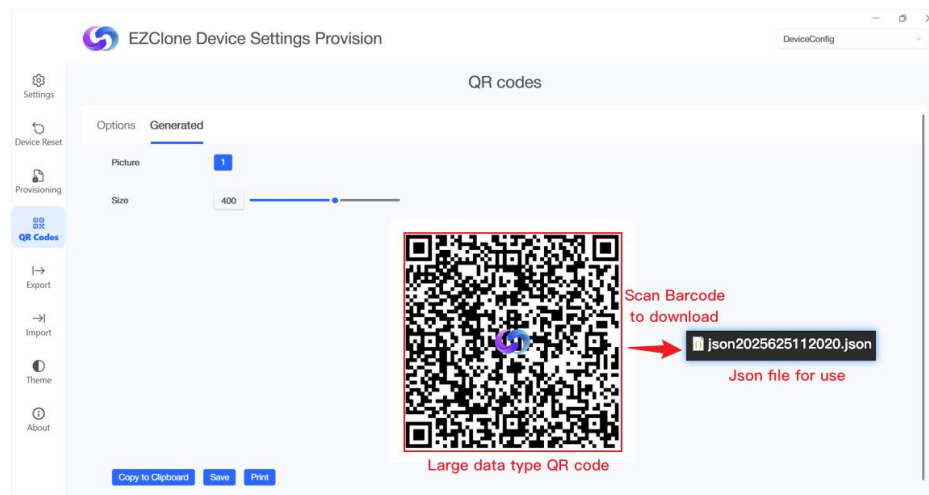

Button [Save] is used to store the barcode image, button [Print] is used to print and button [Copy to Clipboard] is used to copy the image for later use.

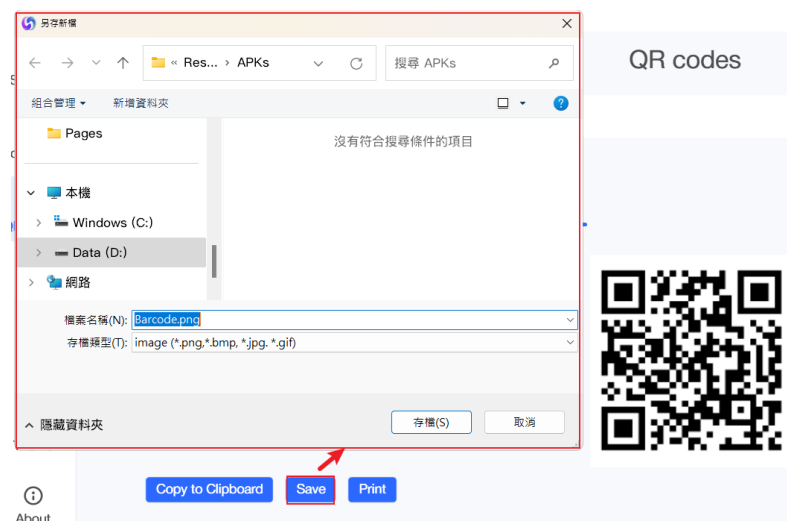

6.1.8 EXPORT PAGE

Button [Export] is to save the device config setting decided by your own.

Button [Select All] and [Unselect All] are used to include or exclude Setting categories.

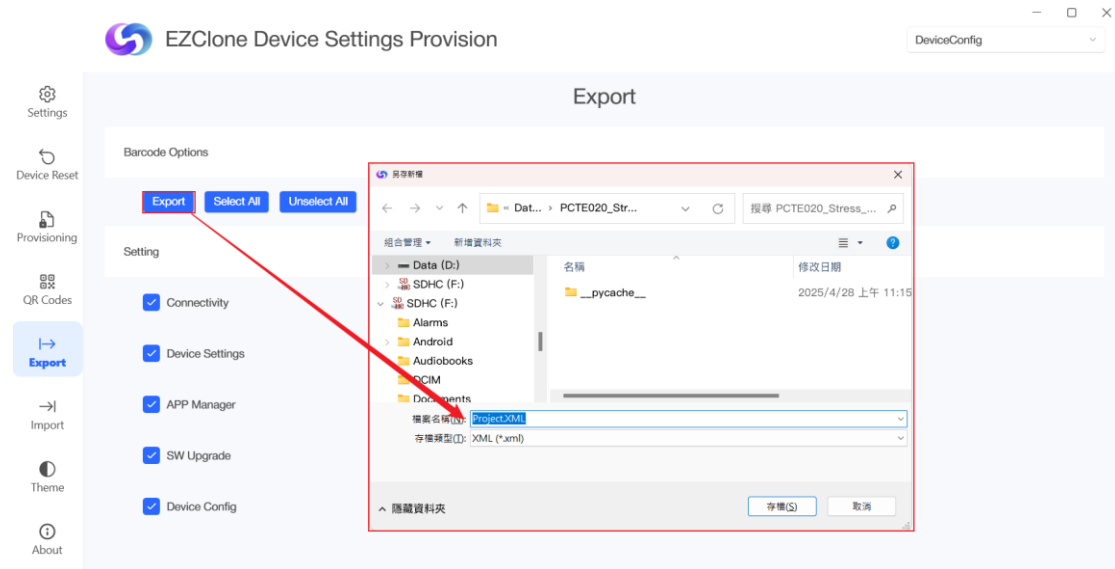

6.1.9 IMPORT PAGE

There are 5 kinds of data types to import on this page.

- (1) APK Files
- (2) XML Files
- (3) FOTA Files
- (4) BootAnimation
- (5) INIFileConfig

Click button [Choose File] will pop up a dialog to select the file.

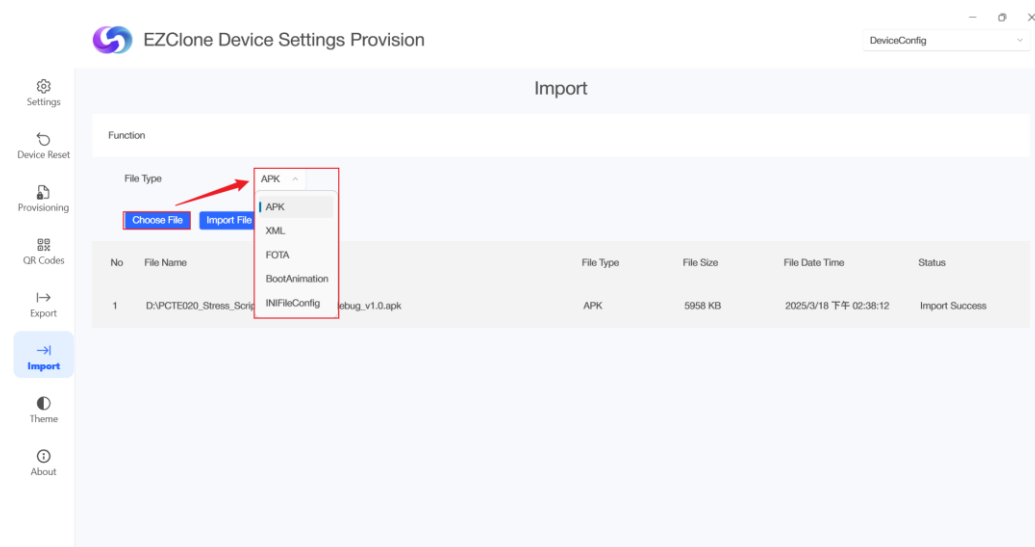

After the file is selected, the default status is [waiting import], click button [Import File] will try to import the file in the list.

Observe the Status field to check the import action is OK with [Import Success] or NG with [Import Fail].

The screenshot shows a file import interface. At the top, there is a table with columns: File Type, File Size, File Date Time, and Status. The first row shows a file named 'APKs File' with a size of 2948 KB, dated 2022/8/9 下午 01:35:54, and a status of 'waiting import'. Below the table, there are three buttons: 'Choose File', 'Import File', and 'Clear List'. The 'Import File' button is highlighted with a red box. Below the buttons, there is another table with the same columns. The first row shows 'APKs File' with a size of 2948 KB, dated 2022/8/9 下午 01:35:54, and a status of 'Import Fail'. The second row shows 'XML File' with a size of 28 KB, dated 2025/1/17 上午 11:55:54, and a status of 'Import Success'. Red arrows point from the 'Import File' button to the 'Import Fail' and 'Import Success' status cells.

File Type	File Size	File Date Time	Status
APKs File	2948 KB	2022/8/9 下午 01:35:54	waiting import

File Type: XML Files

Buttons: Choose File, Import File, Clear List

File Type	File Size	File Date Time	Status
APKs File	2948 KB	2022/8/9 下午 01:35:54	Import Fail
XML File	28 KB	2025/1/17 上午 11:55:54	Import Success

Button [Clear List] is used to clear the list.

The screenshot shows the same file import interface as above. The 'Clear List' button is highlighted with a red box. Below the buttons, there is a table with columns: No, File Name, File Type, File Size, File Date Time, and Status. The table is currently empty. A red arrow points from the 'Clear List' button to the table.

Function

File Type: XML Files

Buttons: Choose File, Import File, Clear List

No	File Name	File Type	File Size	File Date Time	Status
----	-----------	-----------	-----------	----------------	--------

6.1.10 THEME PAGE

The Current Palette shows the current color theme, 4 kinds of color theme are defined in Customized (Technology / Consumer / Askey / Mystery) to choose from.

The screenshot shows the 'Theme' page in the 'EZClone Device Settings Provision' application. The page has a sidebar with navigation options: Settings, Device Reset, Provisioning, QR Codes, Export, Import, Theme (selected), and About. The main content area is titled 'Theme' and contains three sections: 'Current Palette', 'Mode', and 'Customized'. The 'Current Palette' section shows 'Technology (Default)' with a blue color swatch. The 'Mode' section has two radio buttons: 'Day Mode' (selected) and 'Night Mode'. The 'Customized' section has four radio buttons: 'Technology' (selected), 'Consumer', 'Askey', and 'Mystery', each with a corresponding color swatch. A red box highlights the 'Technology (Default)' option in the 'Current Palette' section.

EZClone Device Settings Provision

DeviceConfig

Theme

Current Palette

Technology (Default)

Mode

Day Mode

Night Mode

Customized

Technology

Consumer

Askey

Mystery

Day mode / Night mode is provided as you like.

Ex: Night mode + Askey color theme

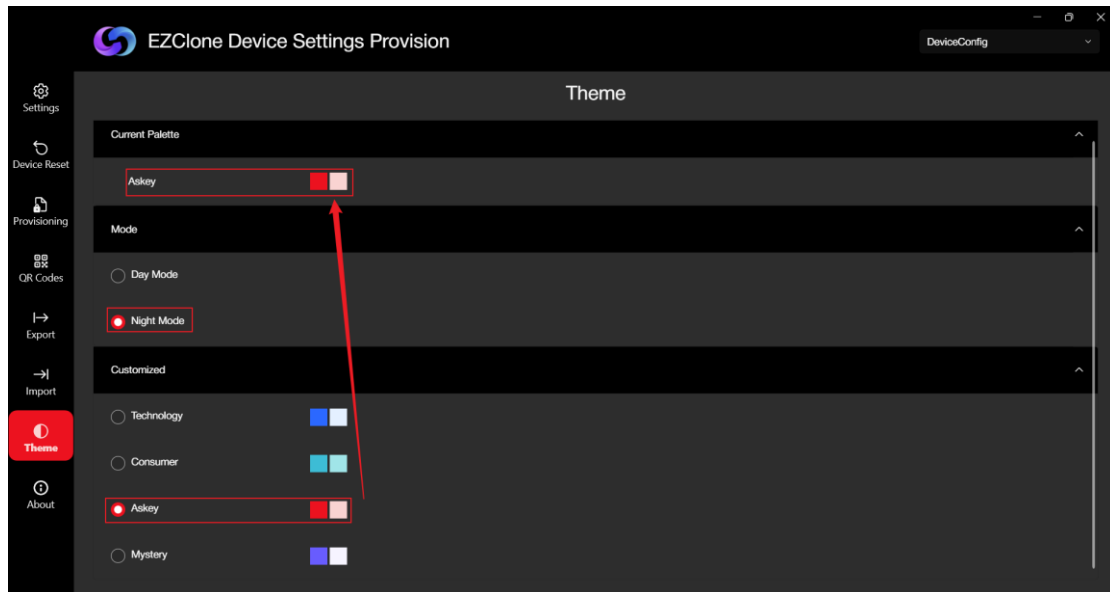

6.1.11 ABOUT PAGE

The software version and build information can be viewed on this page.

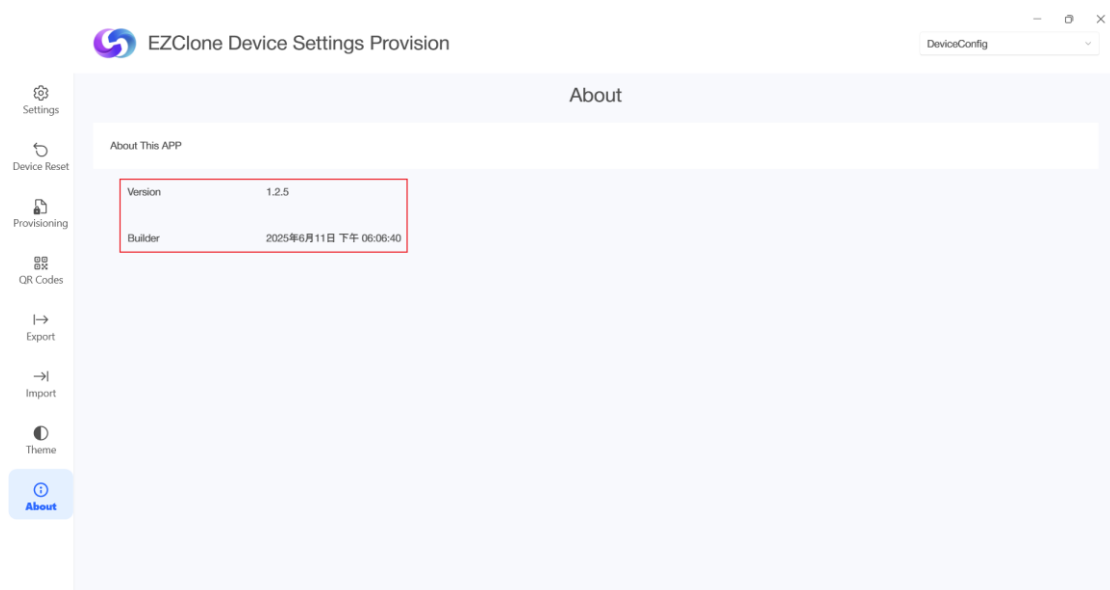

6.1.12 DEVICE EZCLONE APP

The Workstation set device result display

(A) Set up success

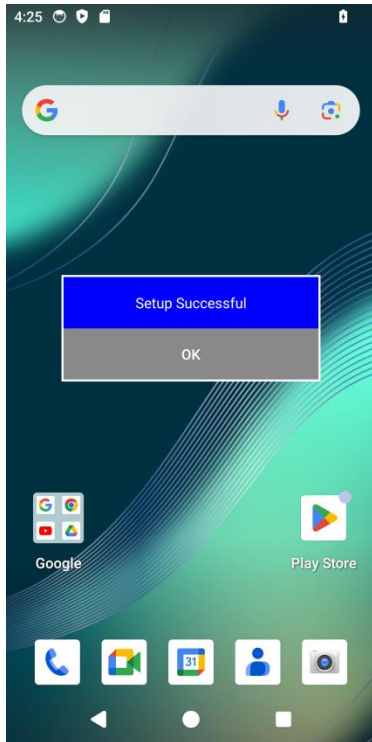

(B) Setting failed

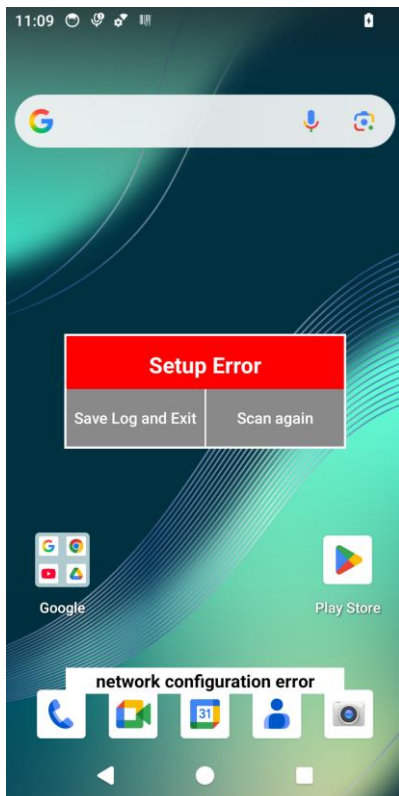

Save Log and Exit: in home -> Files -> Internal storage, find setting_log.txt file

6.1.13 START FIRMWARE UPGRADE

Upgrade software version through workstation

Step 1

Import Upgrade Package to workstation

In the **Import** field, select **File Type** as **FOTA**, click **Choose File** to import the update package from your local device to the workstation, then click **Import File** to complete the process.

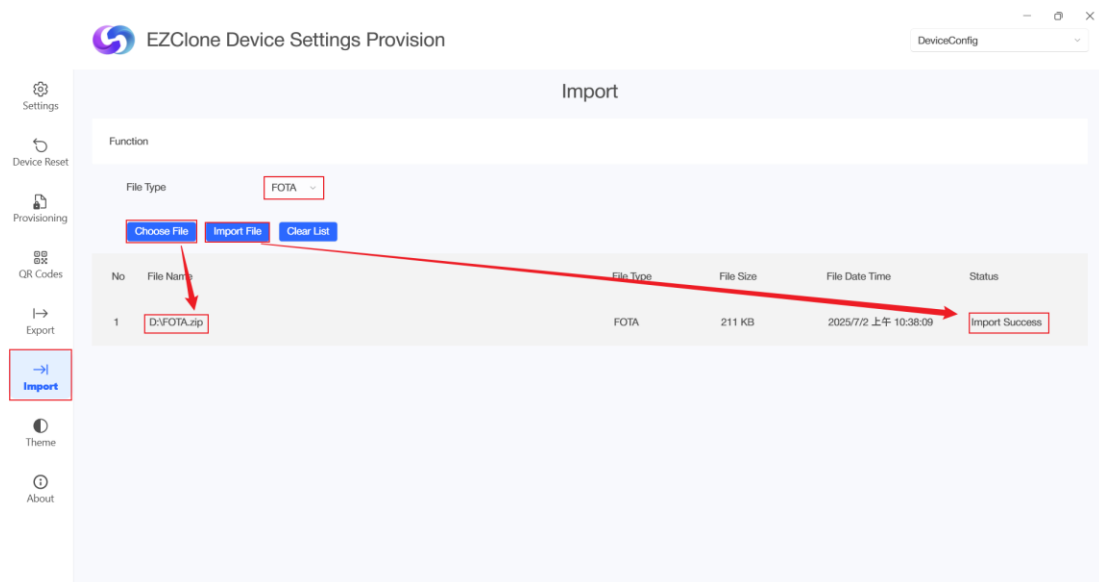

Step 2

Start server

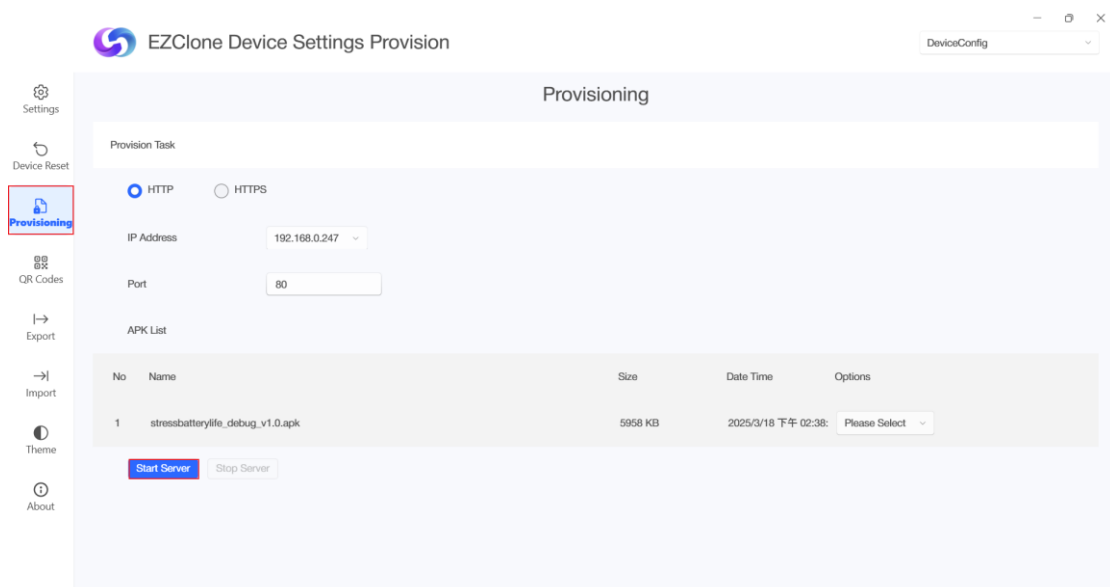

Step 3

Generate the QR code:

- Under **Settings**, select **SW Upgrade**, reload the update file imported in **Step 2**, and enable **FOTA**.
- Under **QR Codes**, select **SW Upgrade**, then click **Generate QR Code**.

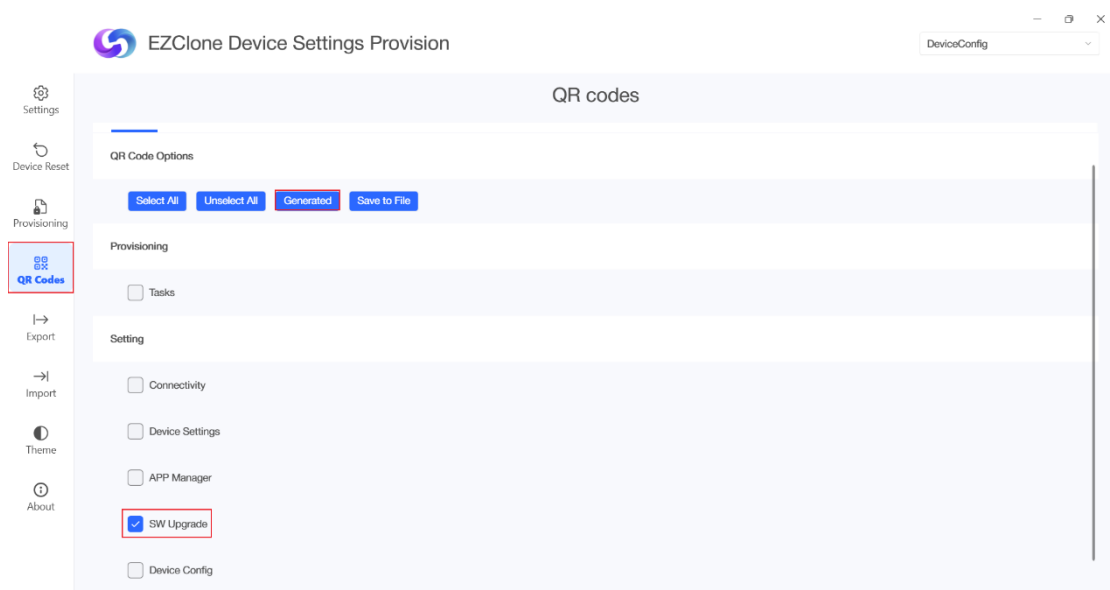
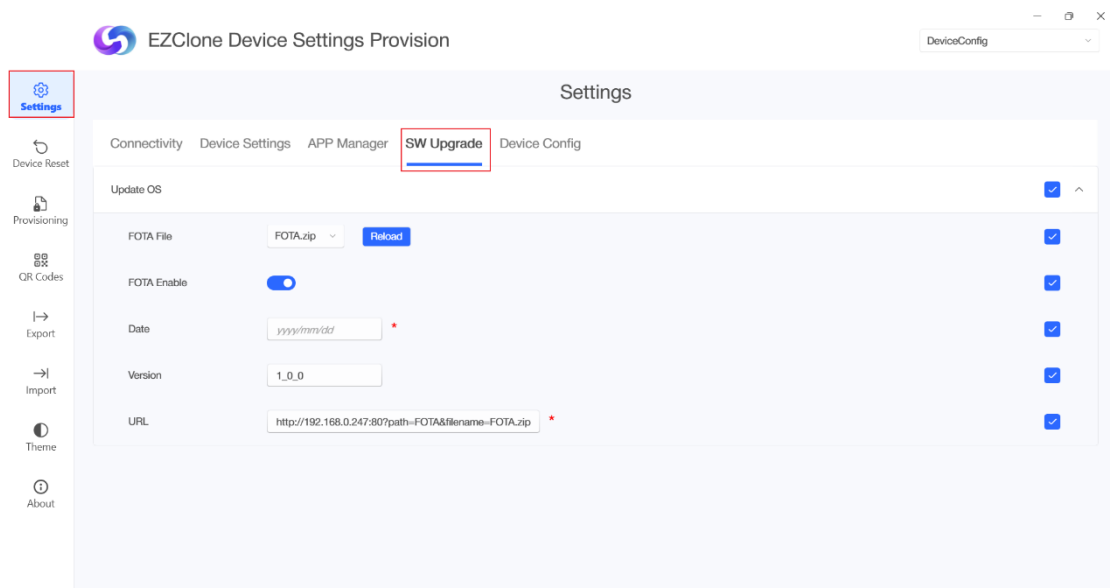

Step 4

Use the device to scan the QR code. The device will download the update package automatically, perform the upgrade, reboot upon completion, and display a "Update success" message.



6.1.14 UPGRADE SOFTWARE VERSION THROUGH SYSTEM SETTINGS

In device Settings -> System -> System update

1. Check for upgrade

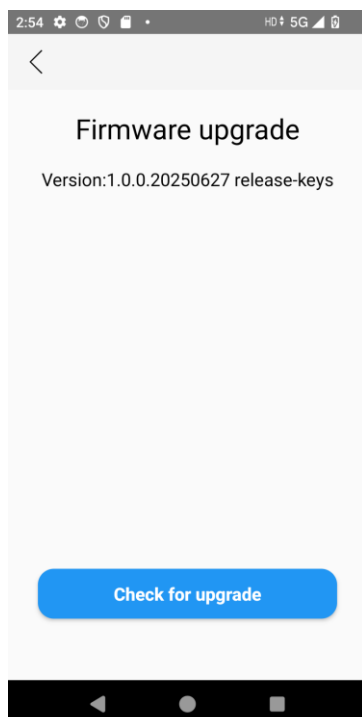

2. Download the upgrade package from the FOTA server.

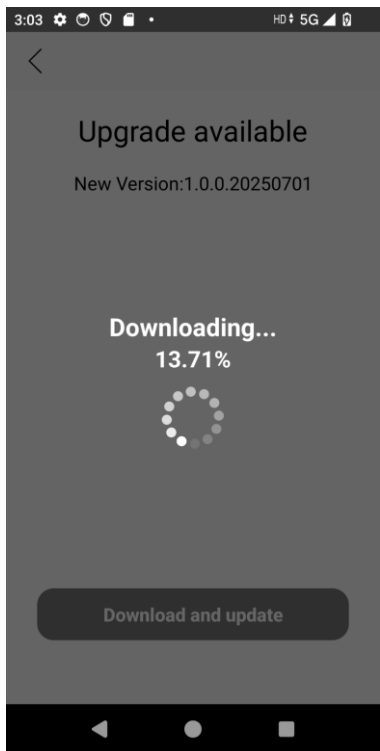
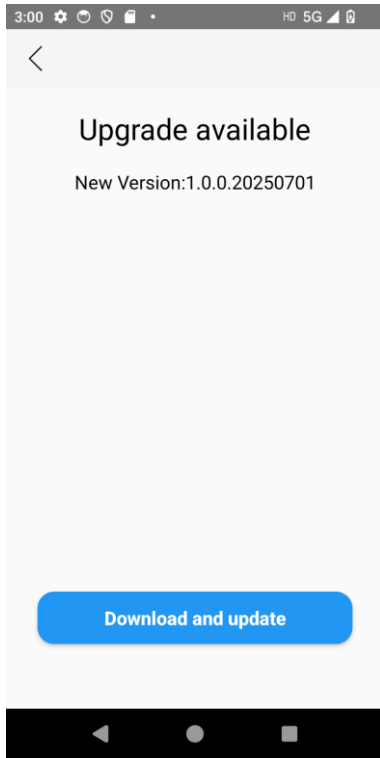

3. Installation completed and restarted

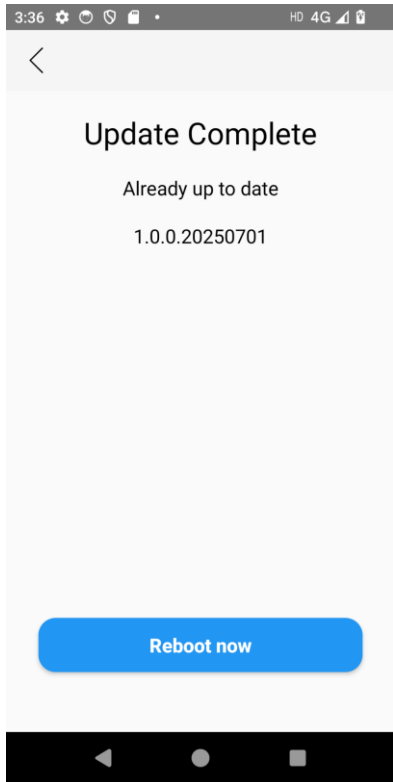

4. Complete the upgrade after restarting

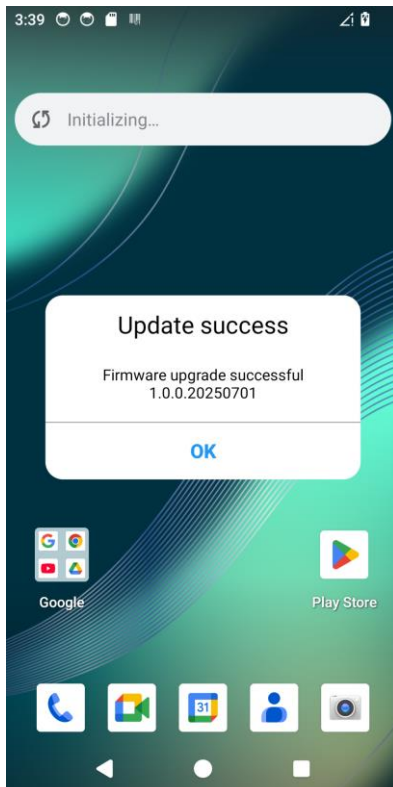

6.2 EZ PTT USER GUIDE

6.2.1 ABOUT EZ PTT

EZ PTT is a client to create Push-To-Talk (PTT) communication for user, leveraging existing Wireless Local Area Network (WLAN) infrastructure, this solution delivers simple PTT communication without the need of a voice communication server

6.2.2 MAIN FUNCTION

Currently, the main function has 3 navigation pages for use

- (1) Contacts
- (2) Group Calls
- (3) Settings
- (4) Private Calls

6.2.3 GROUP CALLS

Group Call - One to Many.

(A) Select a channel and join in

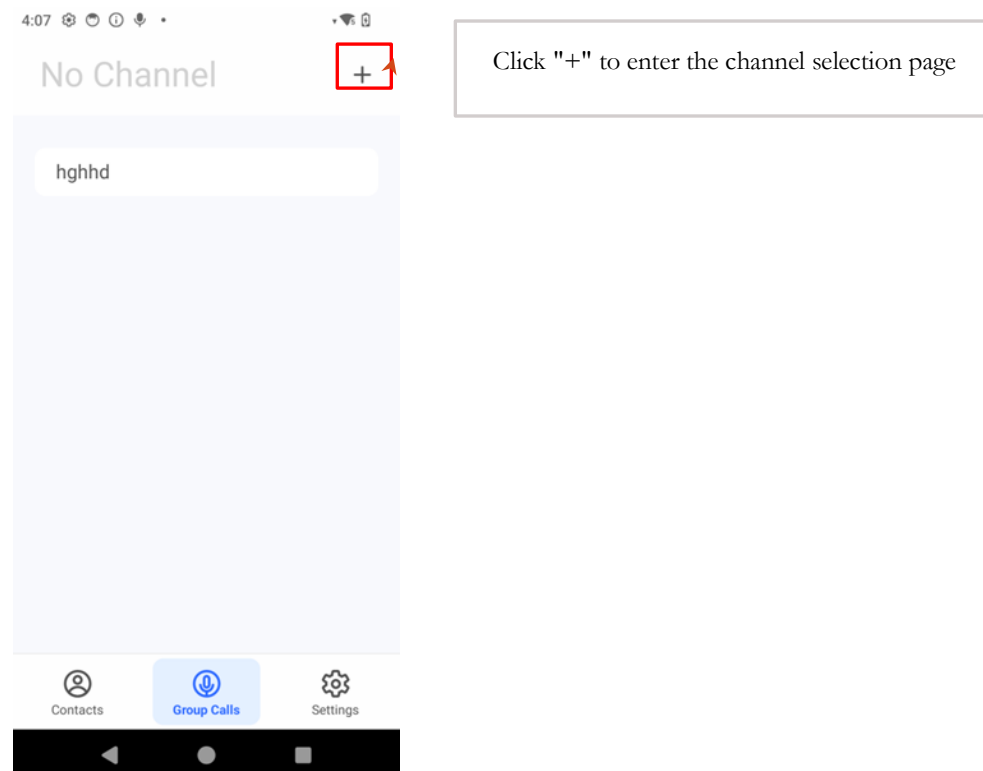

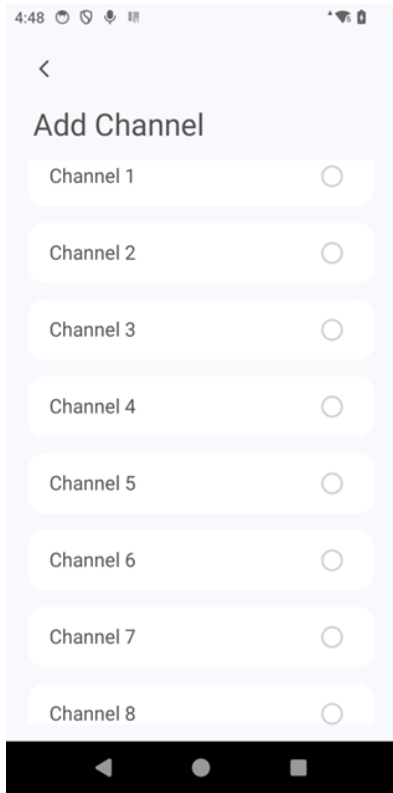

Group call chat interface

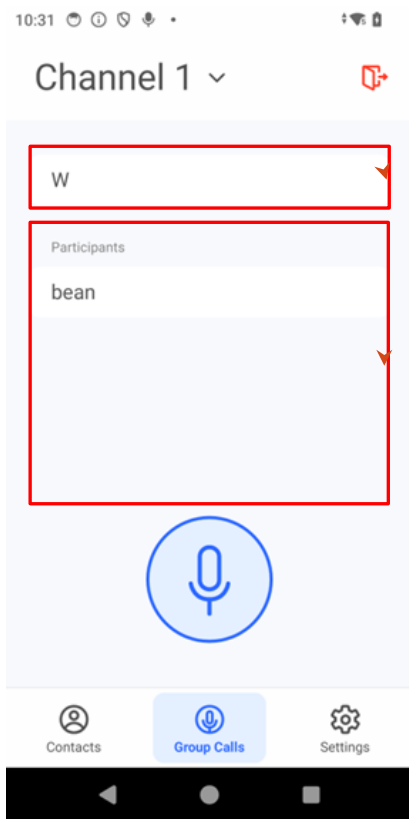

User name

Participant information

(B) Chat operation

Software button : Press and hold to speak, release to stop speaking

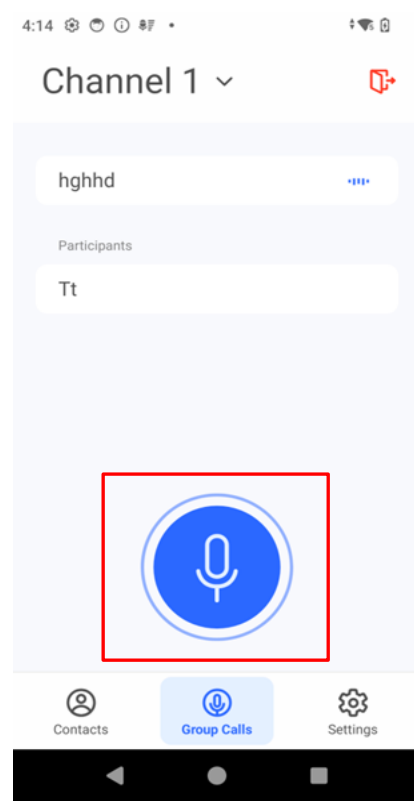

Hardware button: Press and hold to speak, release to stop speaking



6.2.4 CONTACTS PAGE

Display all users in Wireless Local Area Network (WLAN)

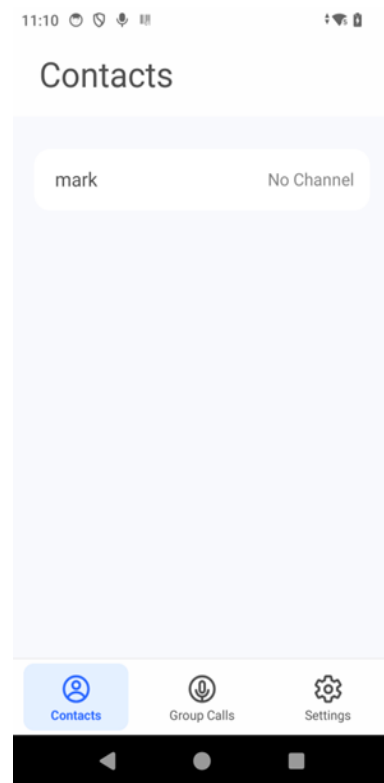

6.2.5 PRIVATE CALLS

Trigger private chat

- (A) In Contacts page, click on the contact's name and request a private chat
- (B) In Group Calls, click Participants name and request a private chat

Request private chat

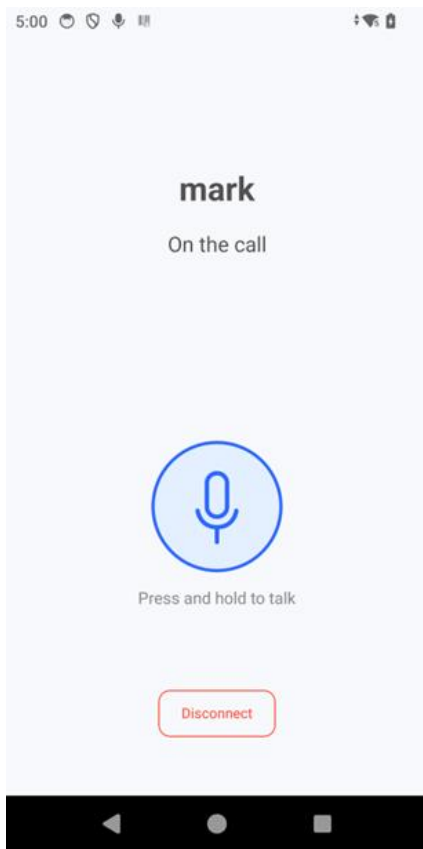
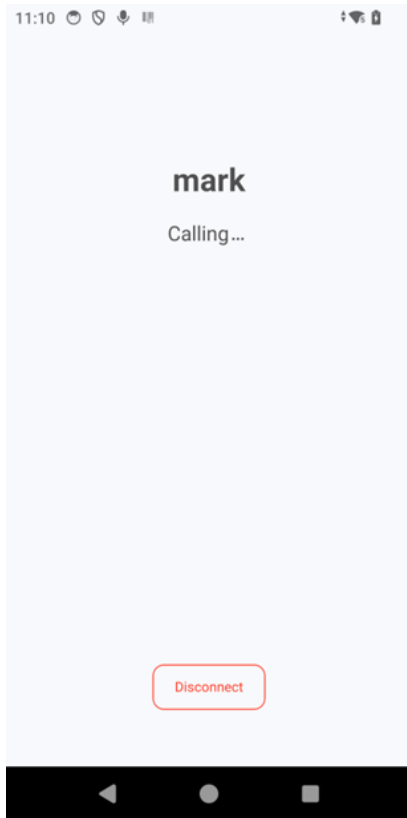

6.2.6 SETTINGS PAGE

Set your PTT application, include About, change Username, set application language,

exit push to talk

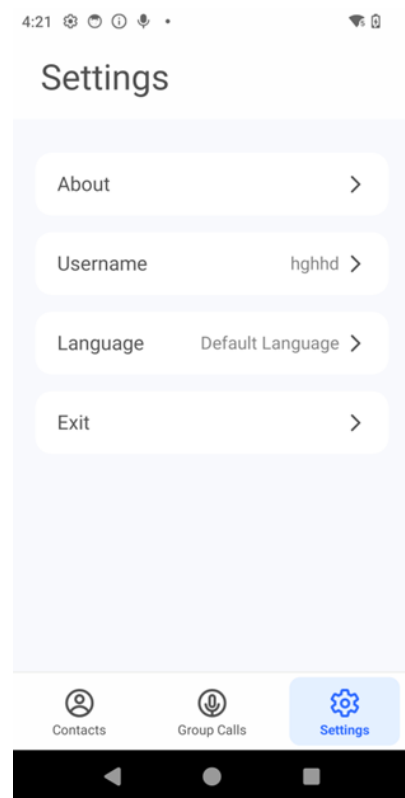

(a) Show application version

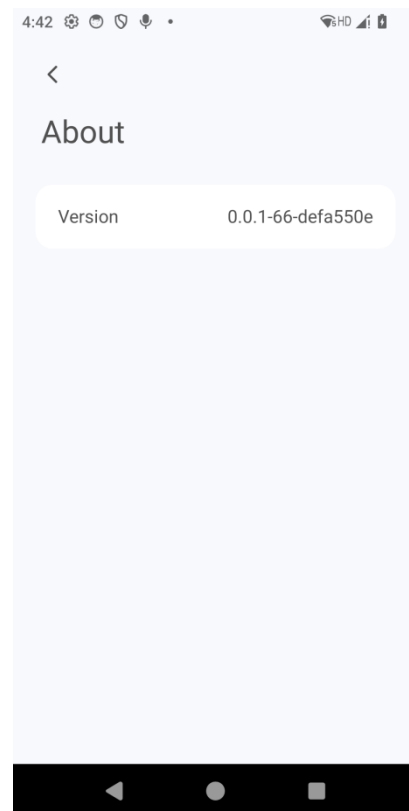

(b) Modify nickname in the application

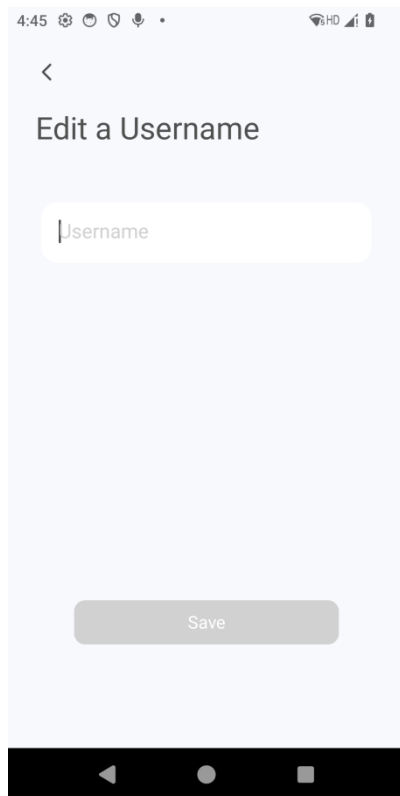

(c) Modify the display language of the application

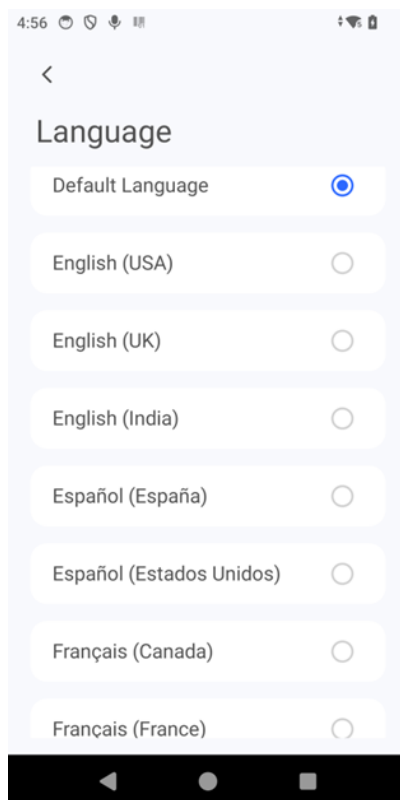

(d) Exit push to talk

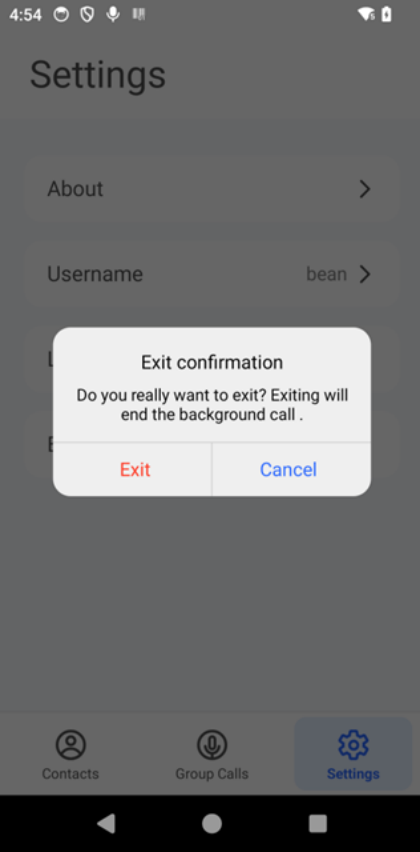

7. ACCESSORIES

7.1 INSTALL HAND STRAP (NEED TO PURCHASE ADD-ON ACCESSORY)

Insert velcro part through both holes and stick on another velcro part. Please adjust the length that you feel comfortable with.

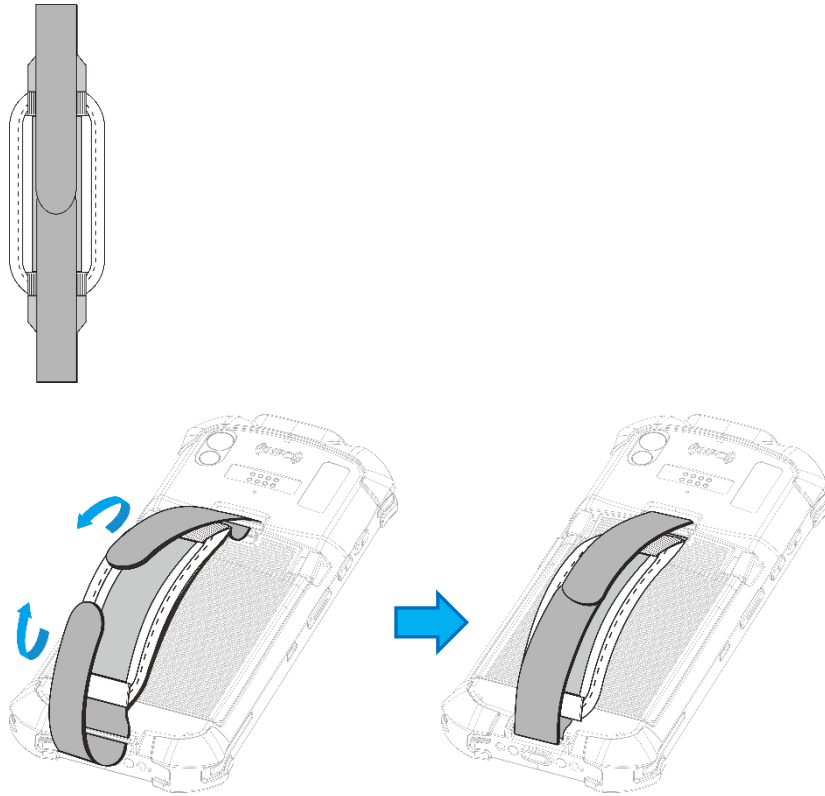

7.2 INSTALL PISTOL (NEED TO PURCHASE ADD-ON ACCESSORY)

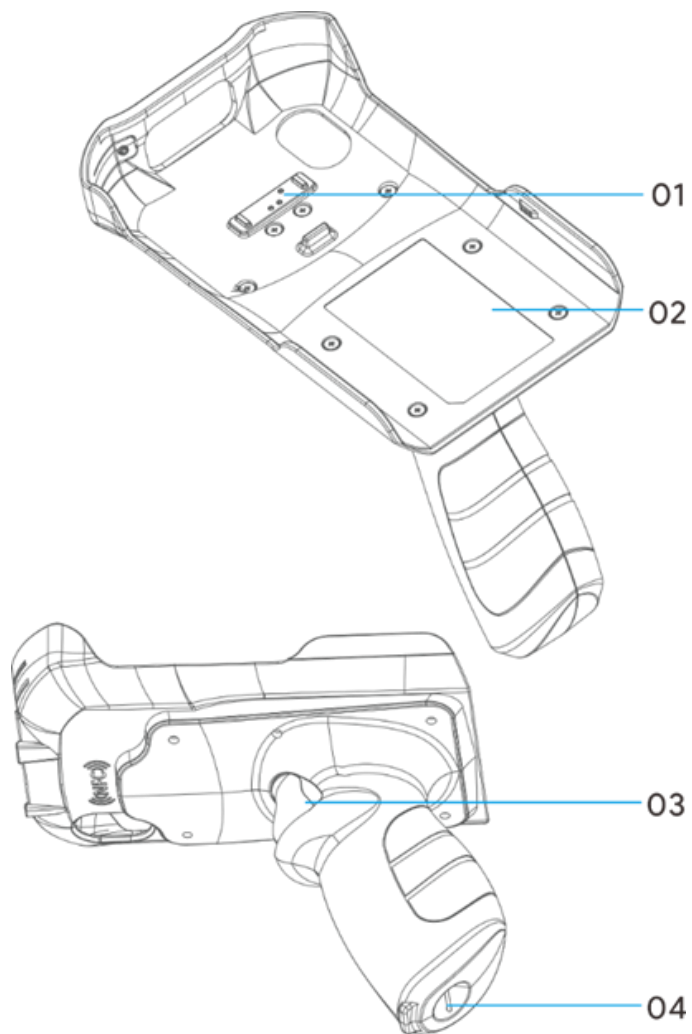

01. Connector	03. Trigger
02. Label	04. Wrist strap support

Install Scan Handle

Put the RC40 mobile computer to prop the scan window of scan handle and push RC40 body down, you will hear click when they are assembly successfully

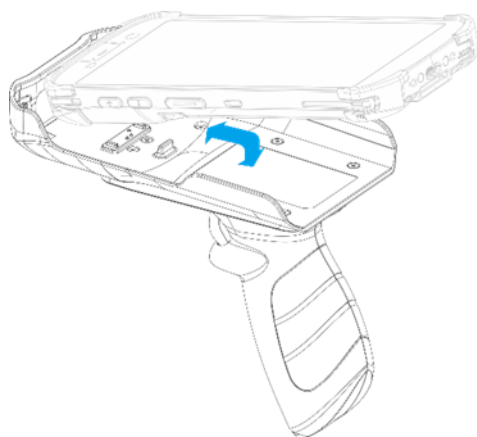

Uninstall Scan Handle

Push one wing and the RC40 mobile computer will jump out from the scan handle automatically and you can take the RC40 mobile computer easily.

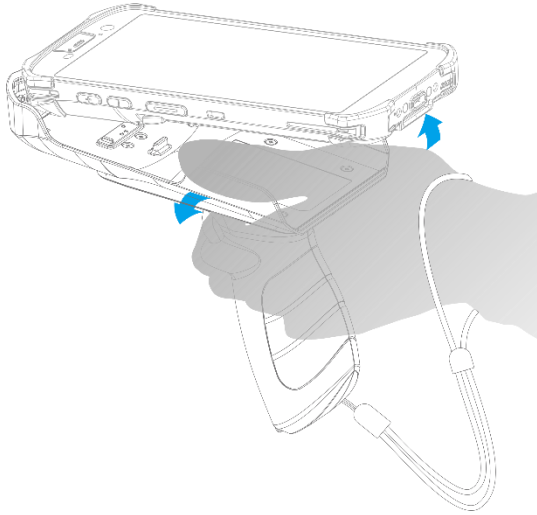

Put on desk

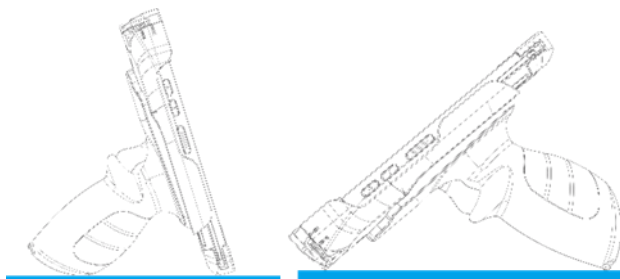

Install Wrist strap (need to purchase add-on accessory)

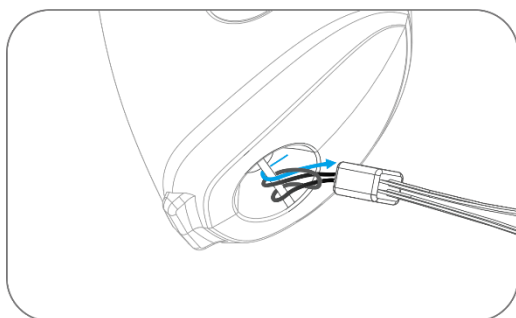

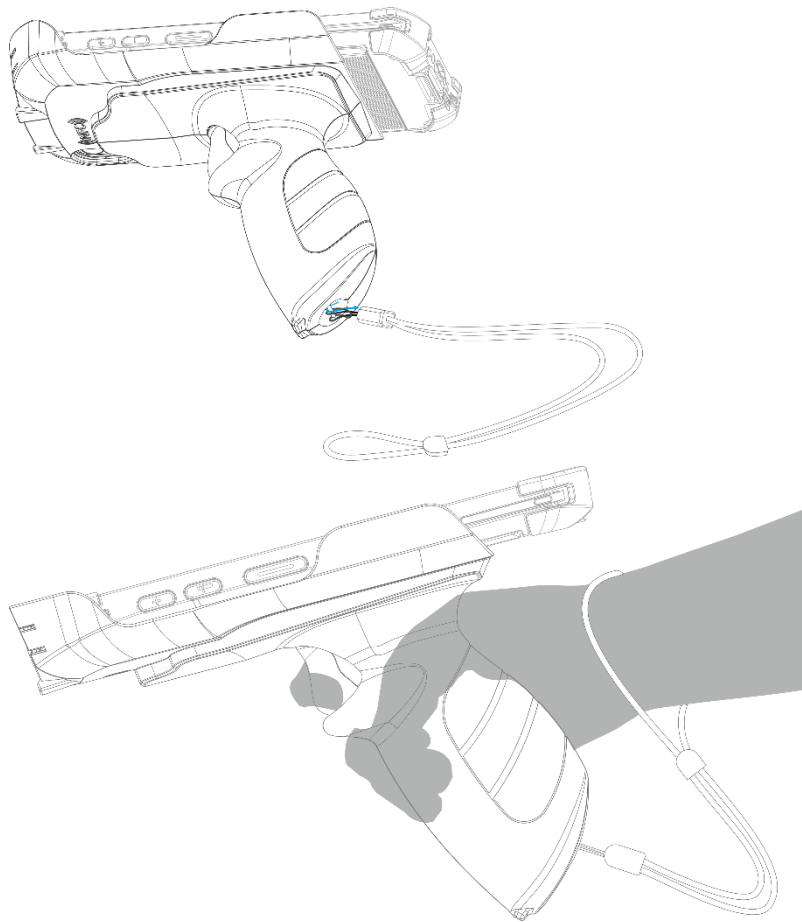

8. MAINTAIN AND TROUBLE SHOOTING

8.1 MAINTENANCE

- When the RC40 is dirty, please use a clean damp cloth to wipe the machine body. Do not use chemical solvents such as detergents, bleach, etc.
- When the screen is dirty, please use a cloth that will not rub the screen and cause scratches.
- Do not damage the screen surface with sharp objects.
- If there is water stain or dirt on the battery, please clean it with a dry cloth before installation.
- Placing the product in an environment with a temperature exceeding the specification will cause damage to the machine.
- If not in use for a long time, please unplug the battery and store the host and battery separately.

Hearing Aid Compatibility (HAC)

This phone is hearing aid compatible as determined by the ANSI C63.19-2019 standard.

The ANSI C63.19-2019 standard does not use the M/T rating system that older versions of the standard used. Instead, this standard uses the conversational gains for the phone’s hearing aid compatible capabilities. For more information regarding FCC Hearing Aid Compatibility, please go to <https://www.fcc.gov/hearing-aid-compatibility-wireless-telephones/>.

The term “conversational gain” is defined as the acoustic output level of speech from a handset relative to the acoustic level that would be present in a face-to-face conversation with two people one meter apart.

The volume control capabilities of this phone have been evaluated according to ANSI C63.19-2019 and FCC limited waiver DA 23-914.

Conversational gain with hearing aids: 11.50 dB

Conversational gain without hearing aids: 18.01 dB

This phone has been tested and certified for use with hearing aids for some of the wireless technologies that it uses. However, there may be some newer wireless technologies used in this phone that have not been tested yet for use with hearing aids. It is important to try the different features of this phone thoroughly and in different locations, using your hearing aid or cochlear implant, to determine if you hear any interfering noise. Consult your service provider or the manufacturer of this phone for information on hearing aid compatibility. If you have questions about return or exchange policies, consult your service provider or phone retailer.

The table below shows the wireless technologies (including frequencies/bands by air interface and codec) that were tested or not tested according to FCC rules and limited waiver DA 23-914 for volume control capabilities:

Codec and air interface combinations that have passed frequency response, and distortion/noise tests.

Voice Service	Air Interface / Band	Codec

VoLTE	LTE: 2/4/5/12/13/14/17/25/26/30/ 38/41/42/43/48/66/70/71	EVS NB/WB 24.4 kbps
-------	---	---------------------

Codec and air interface combinations that have passed Conversational Gain tests.

Voice Service	Air Interface / Band	Codec
CMRS Voice	WCDMA: II/IV/V	AMR NB/WB
VoLTE	LTE: 2/4/5/12/13/14/17/25/26/30/ 38/41/42/43/48/66/70/71	AMR NB/WB
		EVS NB/WB

Codec and air interface combinations that have not been tested.

Voice Service	Air Interface / Band	Codec
VoLTE	LTE: 2/4/5/12/13/14/17/25/26/30/ 38/41/42/43/48/66/70/71	EVS SWB
Google Meet	LTE: 2/4/5/12/13/14/17/25/26/30/ 38/41/42/43/48/66/70/71	OPUS